

Simulation Model of Container Land Terminals

A.L. Kuznetsov, A.V. Kirichenko & J.J. Eglit

Admiral Makarov State University of Maritime and Inner Shipping, St. Petersburg, Russia

ABSTRACT: The simulation as a tool for the design of port and terminals has emerged as an answer for the demand to enhance the quality and reliability of the project results. Very high costs of the project solution implementation and practically total lack of liquidity of transport infrastructure objects always induced the immense commercial risks in the terminal business. Lately these risks have multiplied significantly due to rapid changes on the global and regional markets of transport services. Today, many experts come to see this volatility as an indicator of the next phase in development of the global trade system and the derivative cargo transportation system, specifically the state of temporal saturation. The shift of the global goods volumes from quick and steady growth to relatively small fluctuations around constant values causes quick oscillations in redistribution of demand over the oversized supply. This new business and economic environment seriously affected the paradigm of transport terminal design and development techniques. The new operational environment of terminals put a request for the designers to arrange the results not in terms of "point", but in terms of "functions". Eventually it resulted in development of the modern object-oriented model approach. The wide spread of this approach witnesses the objective demand for this discipline, while in many aspects it remains in the intuitive (pre-paradigm) phase of its development. The main reason for it is in the problem definition itself, which usually is formulated as the simulation of a given terminal. At the same time, the task is to assess the operational characteristics of the terminal engaged in processing of a given combination of cargo flows. Consequently, it is not the terminal that should be simulated, but the processes of cargo flows handling performed by this terminal under investigation. Another problem that restricts the practical spread of simulation is in the model adequacy. A model which adequacy is not proved has nognoseological value at all. The paper describes the approach aimed at development of the models with the features discussed above.

1 INTRODUCTION

The analytical techniques for the assessment of elements' parameters to big systems with complex functional connections [1-2]. The demands for getting more adequate and accurate estimations of characteristics, translated into selected criteria of the quality of the operations, face the stochastic nature both of the values and the mechanisms of their interactions. The necessity to deal with the stochastic

values of all referenced and resulting parameters, along with their inner transformations, push the practice of the terminal design towards the simulation approach.

Correct use of the simulation enables to study the object's behavior (regarded as the evaluation of the parameter values over time), which is the result of the constituting elements interactions through identified ties between them. A determinate algorithm of this

process gives way to an uncontrolled chance interactions of the objects in the “bullion” of software environment selected for the implementation of the model. The result is the resolving behavior of the system’s response to the reference inputs and interfering external influences, studied under different set of the system state parameters. The statistic processing of the received data enables to obtain the integral distribution curves fully describing the parameters as stochastic values. The dynamics observed in the course of the simulation experiments enables to make the judgments over the reliability of the estimations.

Modern container terminals, specifically “dry ports” with extended functionality and complexity, by all means belong to the category of objects, whose behavior cannot be assessed analytically.

This problem is studied by many researchers [3-5], reporting important and useful partial results. At the same time, most often the objectives of these studies are declared as the simulation of the terminals, while the main goal is to simulate the cargo flows on their ways trough the terminals. For sea container terminals these cargo flows and their functional trajectories are relatively standard, while the wide specter of functional profiles of dry ports and land distribution centers causes the wide variety of the correspondent cargo flow structures. In addition, the collection of statistics, input references, experiment planning and interpretation of results meet the lack of the unanimity in the terminology concerning primal cargo flows and their handling on their routes through the terminal.

This study identifies all possible cargo flow classes, which demand different technological resources in different quantities for their handling. For simulation of these flows handling, a generalized universal model of ‘dry port’ type container terminal is introduced. The structural elements of this model forms a unified format for the formal description of technological routs that different classes of cargo follow on their way through the terminal. Splitting of all technological operations into ‘indivisible’ primal moves provides the possibility of an equally formal description of the terminal handling system in terms of the equipment used for these operations. The simplicity of this description significantly reduces the laboriousness of the simulation experiments, which in its turn enables to take extensive studies of the wide variety of cargo handling systems and large sets of possible cargo flows.

Eventually, the discussion of the results provides universal methods of parameter estimations and recommendations on utilization of the object-oriented simulation as a tool for technological design of container terminals.

2 METHODS AND MATERIALS

2.1 Static simulation

Containerized cargo displays certain unique features unknown in conventional transportation. Break bulk could arrive in port loaded in containers, being registered not in tons, but in teus or boxes, thus

mixing with empty containers. Stripped from containers, the break bulk makes the terminal its generating point, simultaneously turning laden boxes into empties. The container stuffing reverts these processes. At the same time, both laden and empty containers are not calculated in tons, as well as the break bulk is not calculated in teus. Containers could be counted both in teus and in ‘physical boxes’.

This ambiguousness of terminology and interpretation used for denoting the most obvious and principally important terminal operations becomes a significant problem not only in planning of national and regional transport systems, analyses of port and terminal efficiency, but also in their technological design [6].

The cargo flows in dry ports by direction could be divided into inbound (crossing the terminal boundary inwards in any place) and outbound (crossing it outwards). This is a principal distinguishing feature between ‘dry’ and ‘sea’ ports, since in the latter the flows are classified by the direction of crossing the berth line (import and export).

By the type of cargo, both inbound and outbound flows could be divided into break bulk and container flows.

By the mean of processing at the terminal, the break bulk and container flows could be divided into straight and conversing ones. The straight flows assume only transportation of cargo through terminal and do not imply the transformation of break bulk into container and otherwise. The conversing flows are represented by two types: inbound flow of break bulk which is transferred into outbound container flow (the stuffing flow), and inbound container flow which is transferred into outbound break bulk flow (the stripping flow). Loading of break bulk into containers demands for the flow of empty containers for stuffing. The stripping of laden containers generates another flow of empty (unloaded) containers. These to inner terminal flows are called concomitant.

The volumes of generated and consumed empty containers could differ, thus demanding the delivery from outside in case of the deficit and dispatch from the terminal in case of the surplus. In addition to the compensation of this difference, a terminal could perform the function of repositioning of the empties between stuffing and stripping sites in the hinterland. Anyway, in addition to straight (non-conversed) flows of break bulk and container, there appears a separate flow of the empty containers.

With all these considerations taking into account, the generalized scheme of cargo flows passing the dry port is introduced in Fig. 1.

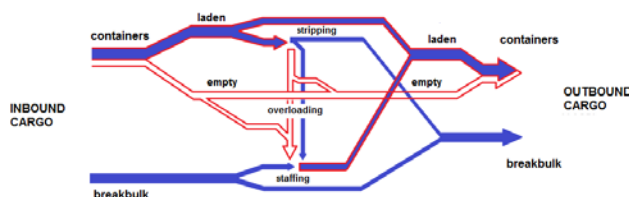

Figure 1. General scheme of cargo flows.

The functional structure of the dry port consists of space-localized processing centers (elements), whose connections correspond to different terminal cargo-handling operations, as Fig. 2 shows.

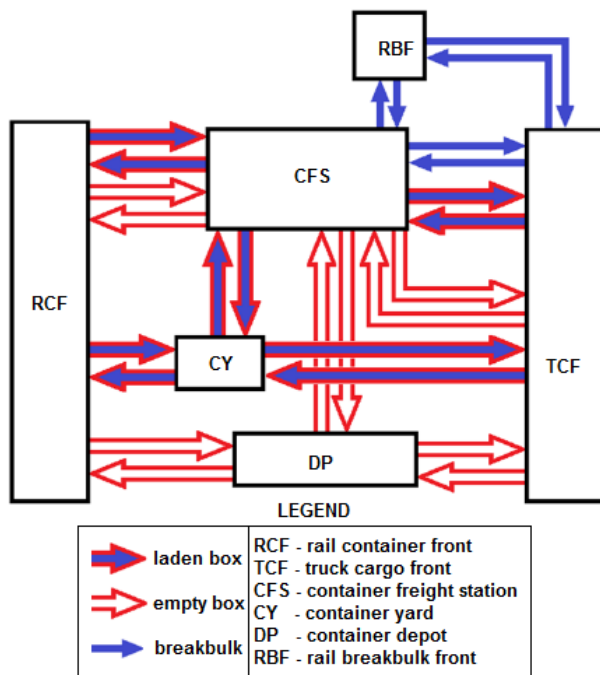

Figure 2. Functional structure and cargo categories.

In other words, the cargo flows shown by Fig. 1 actually pass over the terminal system's elements displayed on Fig. 2. Consequently, every cargo flow from Fig.1 could be described by the sequence of functional elements it passes on its technological route over the terminal, i.e. $\{e_1^k, e_2^k, \dots, e_l^k\}$. In its turn, each pair of adjacent elements from this list (e_i^k, e_j^k) defines one technological operation $l=(i,j)$ of cargo handling, denoted by arrows on Fig. 2.

As a result, knowing the value of a partial cargo flow Q_k over a certain time interval makes it possible to define its technological laboriousness $\{Q_k; e_1^k, e_2^k, \dots, e_l^k\}$, as well as to assess the required

operation volume $l=(i,j)$ for any cargo flow k , or $\{Q_k; (e_i^k, e_j^k)\}$. The knowledge of the total cargo flow structure and volume $\{Q_k; e_1^k, e_2^k, \dots, e_l^k\}$, $k=1, K$ enables to make a perception of the required operation volumes $l=(i,j)$ for the selected time period, or $\{Q^l = \sum_{k=1}^K Q_k; (e_i^k, e_j^k)\}$.

In its turn, every technological operation shown on Fig. 2 could be split into indivisible 'atom' moves [7], performed by one or several species of cargo handling equipment classes (Fig. 3).

Every operation assumes its own consequence of the equipment species $\{t_1^l, t_2^l, \dots, t_L^l\}$, also shown on Fig. 3. The referenced volume of every operation Q^l enables to assess the requirements for the equipment involved in this operation $\{Q^l; t_1^l, t_2^l, \dots, t_L^l\}$.

Summing together the demands for all groups of equipment, it is possible to gain the estimation for the required fleet. The same way the relevant technological resources could be assessed: manning, fuel consumption, electricity, areas, repair and maintenance facilities etc.

At the same time, the actions discussed above describe so-called 'static' model, using for the preliminary estimations of the technological resources over rather long periods, e.g. a season or a year.

All partial cargo flows, represented by their volumes and technological routs, have one equally important characteristin: the distribution over time interval. Every flow could be evenly spread over a period, condense in a part of it, overlap with other or fall into empty fragments. Moreover, the technological resources for partial cargo flows are restricted, which causes the competition of the flows for the resources. In its turn, it leads to extension of the cargo flow processing, delays and queues. This particular mechanism is responsible for the stochastic fluctuations of the terminal operation parameters, which rules out the analytical methods of terminal design.

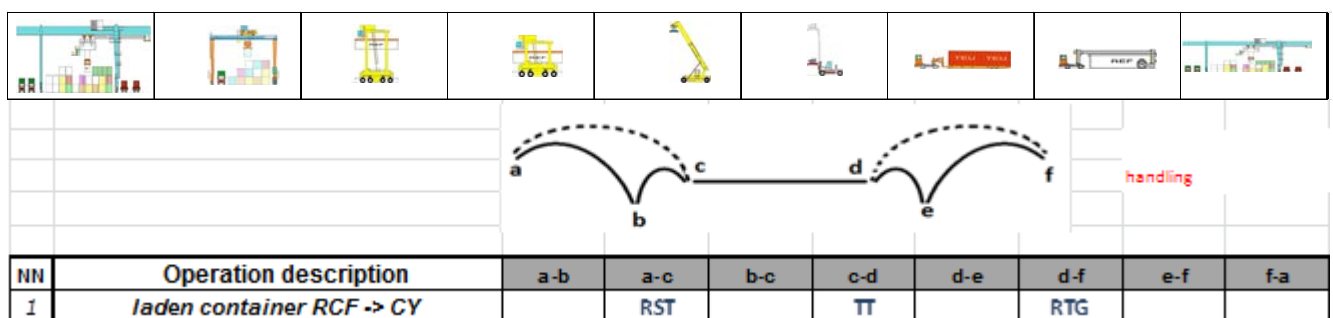

Figure 3. Operation description in terms of primal moves



Figure 4. The screenshot of the simulation monitoring

In order to make judgments over the terminal parameters interpreted as stochastic values, the dynamic or the object-oriented simulation approach is used.

2.2 Dynamic simulation

The dynamic simulation utilizes the same functional model shown on Fig. 2. The principal distinguishing feature is that this model is used for permanent recalculation of all values describing the state of the system on every step of the simulation process. This state depends on the input reference at this moment and the state of the system at previous moments. This statement makes clear that the described paradigm here is so-called discrete event simulation [8].

In order to explain this approach let us consider an example of two cargo flows, whose routes through the terminal are described by the schemata $\{e_1^1, e_2^1, e_3^1, e_7^1, e_6^1\}$ and $\{e_2^2, e_6^2, e_5^2, e_1^2\}$. For certainty, let us assume that e_1^x is the rail cargo front, e_2^x is the pre-stacking area for rail operations, e_5^x is the container yard, e_6^x is the document office and e_7^x is the truck gate to the terminal. The referenced inputs to the model are the train arrivals (flow 1) and truck arrivals (flow 2) to the terminal, generated by various probability patterns. The party size of the arriving cargo q_k is also a stochastic value generated by a selected distribution. Every event under the selected notation are ordered lists $\{q_k^1; e_1^1, e_2^1, e_3^1, e_7^1, e_6^1\}$ and $\{q_k^2; e_7^2, e_6^2, e_5^2, e_2^2, e_1^2\}$. An example of this generation is given by Tab. 1.

At any step of the simulation, the arrival events put the correspondent amount of cargo as a job in the queue for handling by an element. If there is a competitive operational resource allocated for this element at this moment, it collects the correspondent amount of cargo for handling. The jobs processed by the element as the server are directed to the next

element in line defined by the type of the cargo flow, i.e. by the sequences $\{q_k^1; e_1^1, e_2^1, e_3^1, e_7^1, e_6^1\}$ and $\{q_k^2; e_7^2, e_6^2, e_5^2, e_2^2, e_1^2\}$, constituting the model logics.

Table 1. The sample of input flows generation

Time	Input 1	Input 2
1	100	150
2		
3	80	44
4		59
5	100	150
6		120
7	120	66
8	125	34
9	300	78
10		100
11	220	124
12		
13	260	67
14	110	
15		100
16	123	111
17	100	67
18		
19	80	44
20		59

All these operations in the model realization are performed by the standard components – queues, servers, switches etc. The distribution of the equipment pool' recurses $\{t_1^1, t_2^1, \dots, t_L^1\}$ by operations is directed by the established priority of the flows and factual demands for them, defined by the simulation procedure itself. The state of every component of the model reflects the course of operation performance, relevant delays and queues (Fig. 4).

Fig. 5 as an example shows detailed graphics of the jobs waiting in the queue for transportation from the pre-stacking area to the container yard.

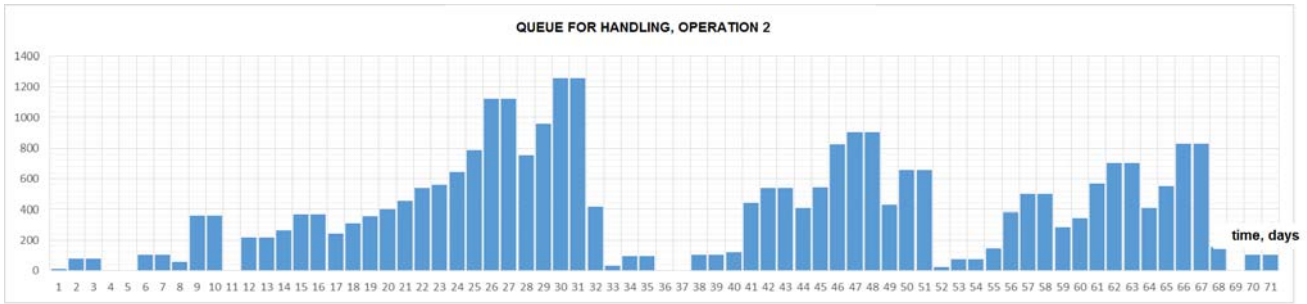

Figure 5. An example of the parameter's dynamics record

Fig. 6 displays the histograms of this parameter's values distributions in the simulation experiments with different priorities of the resources allocation.

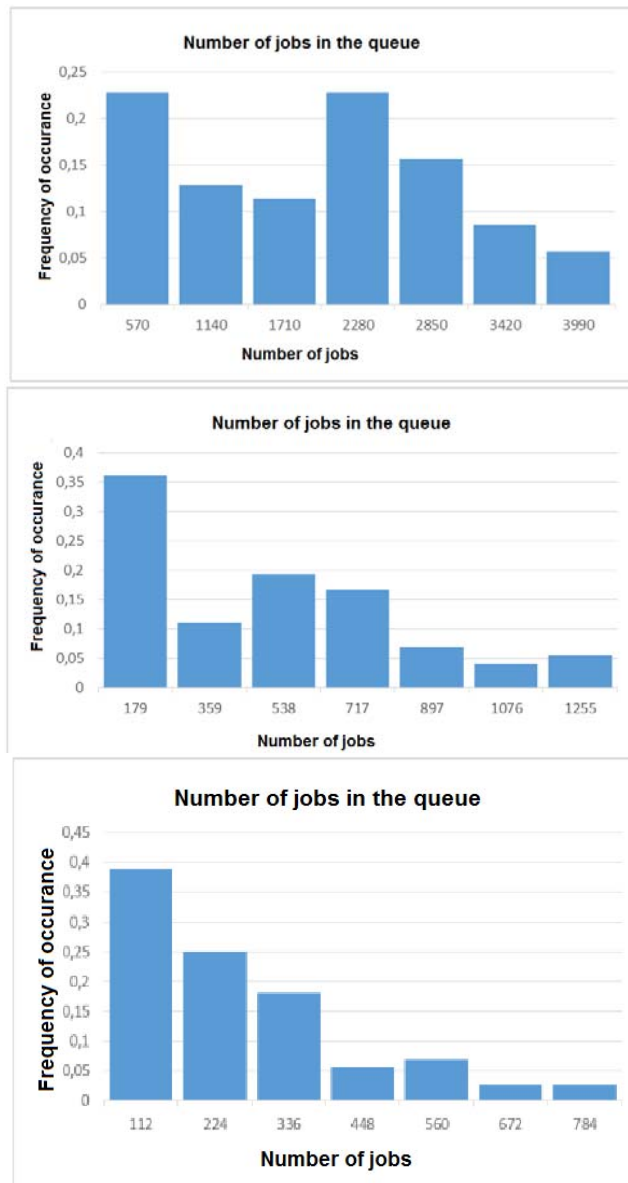

Figure 6. Queue length with different propriety assignment (flow 1 : flow 2)
a) 25:75
b) 50:50
c) 75:20

3 RESULTS

The mechanisms for simulation of the interacting cargo flows shown in the previous section with the help of a simplified example are implemented on the special object-oriented software platform. The interaction of the cargo flows practically means their competition for different technologic resources of the terminal: cargo fronts, warehouse facilities, functional areas, handling equipment, personal etc. For the same cargo flows, the sizes of specific resources and the algorithms of their allocation under deficit led to different values of the terminal parameters, responsible for the quality of the rendered commercial services. By the changing of technological parameters, responsible for quantitative and qualitative characteristics of the terminal, it is possible to reach the desired level of the service quality, commonly measured by the length of the queues, waiting and servicing time. On the other hand, the owner of the terminal using simulation could build the perception of the financial input required to maintain the quality of servicing. In this way, the simulation proves out itself to be an efficient tool to support not only technological, but entrepreneur decisions.

4 DISCUSSION

The modern highly competitive transport business environment, with general deterioration of profitability and growth of cargo flows' volatility, makes the intuitive approaches for taking capital intensive entrepreneur decisions, based upon oversimplified analytical methods, a serious threat for the terminal business. The methodic of the simulation, promising today so much for the business, in many cases comes to realization of a representative example, to a certain extent reflecting a possible variant of a certain demonstrative cargo flow. The quality of the model often is judged not by the size of representative set, or accuracy and reliability of the results, but by the quality of the graphic animation of the model. Actually, this characteristic is one of the less important from gnoseological point of view. The simulation model whose adequacy is not proved has trifling pragmatic value as a tool of design and decision support.

This postulate is the key stone for the whole approach described in this paper and implemented in the practically important software toolkit. The most important component of any design project based on

this methodic is a strict, consistent and coherent proving of the model's adequacy to the primal object, for what the specially designed instruments and methods are used. Only after a very careful validation, thorough calibration and sufficient verification the model could be used as a working tool.

The utilization of the carefully adjusted mechanisms of the object-oriented simulation, reached in the course of the adequacy proving procedure and in the process of rationally planned movement to the clearly stated goal met every expectation in several large infrastructural projects dealing with 'dry port' container terminals. The experience gained during this study enabled to adjust the performance of this design mechanism and rectify the methodic of its application.

5 CONCLUSIONS

- 1 Traditional approaches declare the terminal simulation as their goal, while it is necessary to simulate the cargo flows passing through the terminal functional system.
- 2 Sea and dry container terminal differ cardinally by the structure, content and functional designation of their elements, which requires to develop different model for them.
- 3 A generalized universal model structure is introduced, oriented on a wide class of container terminal of the 'dry port' and distribution center types.
- 4 A universal format for description of typical cargo flows passing the terminal along different technological routes and utilizing its functional elements in different way is suggested.
- 5 A universal format for functional operations description in terms of the engaged technological equipment is introduced.
- 6 These universal means of the cargo flows and description of the required transport and technological equipment enable to study various cargo-handling systems under different scenarios easy and efficiently.
- 7 Since any simulation is only an instrument of analyses, the procedure of synthesis should be

constructed as a directed changing of technical parameters, with simulation as a tool for the comparative study of their values.

- 8 This controlled search in the range of possible solutions takes a form of typical scenario generation, under which the simulation experiments are planned and performed to provide the statistical reliability.
- 9 The described techniques are implemented in the form of dedicated software with practical recommendations on their use.
- 10 The simulation approach for the technological design discussed in the paper has proved its worthiness by utilization in several big transport infrastructure projects.

REFERENCES

- Alexnader L. Kuznetsov. Genezis agentnogo imitazionnogo modelirovania v hode razvitia metodov technologicheskogo proektirovania portov I terminalov / *Exploatazia vodnogo transporta*. N 4(58) 2009, c.3-7
- Alexnader L. Kuznetsov. *Morskaja kontejnernaia transportno-technologicheskaya sistema/* St.Petersbur: MANEB print. house, 2017. – 320 c.
- Nevins, M. R., C. M. Macal, R. Love, and M. J. Brogen. 1998. Simulation, animation and visualization of seaport operations. *SIMULATION* 71 (2): 96-106.
- Legato P. A simulation modelling paradigm for the optimal management of logistics in container terminals. P. Legato, R. Trunfio // *Proceedings of the 21st European Conference on Modelling and Simulation*. Prague, Czech Republic. P. 479–488.
- Najib M. A container terminal management system / M. Najib, A. El Fazziki, J. Boukachour // *Proceedings of the International Conference on Harbour Maritime and Multimodal Logistics M&S*, 2012. P. 118–127.
- Alexnader L. Kuznetsov. *Evoluziya pokazateley harakterisujushih rabotu morskikh portov i terminalov* // *Vestnik GUMRF*. - 2015. - №6(34). - C. 7-16.
- Alexander Kuznetsov. Classification of modern container handling technologies / *Cargo systems*, June 2009, pp.32-33
- P. Hester, S. Diallo. 2014. "Towards a Theory of Multi-method M&S Approach: Part I." In *Proceedings of the 2014 Winter Simulation Conference*, edited by A. Tolk, S. Diallo, I. Ryzhov, L. Yilmaz, S. Buckley, and J. Miller, 1652-1663.