

Research on Radiation Characteristics of Plasma Yagi Antenna Based on AIS base station in Ships' Routeing Waters

Y. Sun, Y. Chen, F. Kong, Y. Wei, F. Zhan & J. Zhao

Merchant Marine College, Shanghai Maritime University, Shanghai, China

ABSTRACT: A Yagi plasma antenna model was established by HFSS according to the relationship between plasma dielectric constant and electron density. The patterns were simulated by changing plasma parameters and the number of director dipoles. Results show that when the passive vibrators were switched off, the antenna is omnidirectional antenna. The directionality increases with the increase of the number of passive dipole and the main lobe of which narrows down. Then the plasma Yagi antenna model is established by plasma tube, the gain changed by changing the number of passive dipoles, so the plasma Yagi antenna has a very good reconfigurability. Results prove that the feasibility of the plasma Yagi antenna can be used on AIS base station of Ships' Routeing waters. It can promote the communication and capability of maritime supervision in Ships' Routeing waters.

1 INTRODUCTION

Automatic Identification System (AIS) plays an irreplaceable role in maritime communication [3]. However, the research on antenna of AIS base station still remains in primary stage. Nowadays, omnidirectional metal antenna is adopted on AIS base station in Chinese Ships' Routeing waters. Although it is possible to implement bursts of AIS information, there are also many problems.

- 1 Some Ships' Routeing waters in China, for example in Chengshanjiao Ships' Routeing waters, are more than 25 nautical miles offshore. However, omnidirectional antenna lower the transmitting range of AIS information due to low gain. This issue can be fixed by directional antenna instead of omnidirectional type.
- 2 In AIS base station communication system, the omnidirectional transmitting antenna power is above 20W, which has strong electromagnetic interference with shore facilities and users.

- 3 Due to the increased traffic density in the ships' routeing waters, communication channels are often occupied and time slot conflicts happened occasionally which greatly increases the burden on the VTS attendant. Therefore, the AIS shore station can utilize VHF high-gain directional antennas to enhance the communication effect of the AIS base station and the VHF shore station.

We propose the idea of applying the electronically controlled plasma Yagi antenna in the field of maritime intelligent communication as the transmitting antenna of the AIS base station in ships' routeing waters to improve the problems above-mentioned. A plasma antenna is an antenna that uses a plasma instead of a metal antenna element as an electromagnetic energy conducting medium [4,5]. Compared with metal antennas, plasma antennas have the characteristics of light weight, good stealth performance and reconfigurability [6,7]. Using the plasma to construct the Yagi antenna, when the

passive vibrators are all turned off, the antenna system only has the active vibrator, which is an omnidirectional antenna. When changing the plasma parameters and increasing the number of directors, the antenna directivity can be dynamically adjusted and communicate in different region. Compared with the metal Yagi antenna, the plasma Yagi antenna has the advantages of reconfigurability and low mutual coupling.

2 MODEL AND PROTOTYPE OF PLASMA ANTENNA

The AIS base station plasma Yagi antenna model includes: an active plasmon, a passive plasmon. According to the plasma antenna theory, it is assumed that the plasma has a uniform axial and radial distribution, and its relative dielectric constant is [8,9]:

$$\varepsilon_r = 1 - \frac{\omega_{pe}^2}{\omega(\omega + i\nu_{en})} \quad (1)$$

where ν is the collision frequency of electrons and neutral particles in the plasma, ω is the angular frequency of the incident electromagnetic wave, ω_{pe} the plasma angular frequency. which can be written as:

$$\omega_{pe} = \sqrt{\frac{e^2 n_0}{\varepsilon_0 m_e}} \quad (2)$$

Assuming the plasma collision frequency is very low, then the plasma relative dielectric constant can be written as:

$$\varepsilon_r = 1 - \frac{\omega_{pe}^2}{\omega^2} \quad (3)$$

When the signal frequency is less than the plasma frequency, $\varepsilon_r < 0$. The electromagnetic wave can propagate between the outer surface of the plasma and the inner surface of the dielectric tube as a surface wave and it cannot propagate in the plasma. And the electromagnetic wave propagating in the radial direction is rapidly attenuated. At this time, the plasma can propagate electromagnetic waves as an antenna.

The HFSS is used to construct the plasma-guided antenna model. According to formulas (1) and (3), the appropriate dielectric constant is selected according to the plasma electron density and collision frequency. The antenna center frequency selects two communication frequencies of AIS, 161.975 MHz and 162.025 MHz respectively. The antenna pattern is simulated by changing the plasma parameters and the number of directors. The plasma Yagi antenna model is shown in Figure 1. The designed antenna consists of an active vibrator, a passive reflector, and three passive directors. Since there are more than five passive oscillators, the gain of the antenna does not change much. Here, in order to highlight the obvious

reconfigurable characteristics of the antenna, only three passive directors are selected.

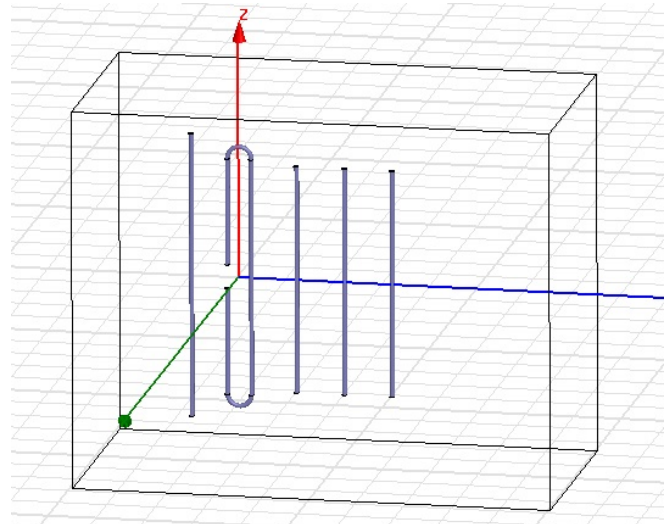

Figure 1. Plasma Yagi antenna simulation model

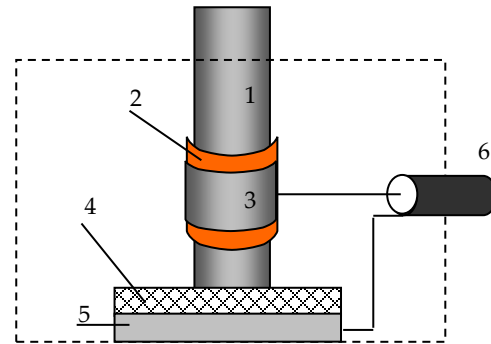

Figure 2 Schematic diagram of plasma capacitive coupling feed mode. 1. plasma, 2. discharge tube, 3. coupling collar, 4. Dielectric layer, 5. Ground plane, 6. Coaxial line

Since the plasma has a certain potential inside, it cannot be fed by direct connection coupling. The feeding mode of the antenna is shown in Fig. 2. The outside of the antenna is a tempered glass cavity, and the active oscillator adopts a capacitive coupling feeding mode. The metal collar is tightly wrapped around the outside of the tempered glass cavity, and the internal plasma forms a coupling capacitor, which is simulated by changing the working state of the passive oscillator. At the same time, the physical model of the plasma antenna was built by using the discharge tube. The plasmon electron density can be adjusted by adjusting the operating state of the power supply. Figure 3 is a schematic prototype of a plasma Yagi antenna. The antenna prototype has a reflective vibrator, an active vibrator, and three passive directors, wherein the antenna active oscillator uses a half-wave folded oscillator. All antenna elements have an outer diameter of 12 mm and an inner diameter of 10 mm, all excited by a 20 kHz high-voltage excitation source, and the excitation power can be adjusted. According to the gas discharge Penning effect, the filling gas inside the discharge tube is helium gas and a small amount of argon gas. The antenna bracket and the movable collar are used to fix the active and passive vibrators of the plasma

Yagi antenna, and the movable collar can move along the axial direction of the bracket to adjust the distance between the antenna vibrators. Antenna vibrators of different lengths can be replaced. Therefore, the antenna prototype can adjust the directivity and impedance bandwidth of the antenna by adjusting parameters such as discharge state, antenna vibrator spacing, and the vibrator length.



Figure 3/ Plasma Yagi antenna principle prototype

3 RESULTS AND ANALYSIS

3.1 Impedance bandwidth characteristics

The largest electron density of glow plasma can reach 10^{18} m^{-3} , the electron density of plasma driven by 20 kHz power supply is from 10^{15} - 10^{17} m^{-3} measured by Langmuir probe [14]. The axial and radial changes of plasma electron density are very small for two ends excitation. So, in the HFSS simulation, the axial and radial electron density is considered to be uniformity. Figure 4 and 5 show the results of simulating and measuring impedance bandwidths when the electron density reaches 10^{16} and 10^{17} m^{-3} respectively. The antenna impedance experimental field is a wide playground, the transmitting antenna is a plasma Yagi antenna, and the receiving antenna is a metal antenna. At this time, all the antenna oscillators are activated. The testing instrument is the vector network analyzer (Agilent, E5071C), and the working frequency is AIS1 (161.975 MHz). The length of reflection oscillator is 0.52 wavelength, the effective length of active oscillator is 0.48 wavelength, the three passive leading oscillators are equal length and 0.45 wavelength, and the distance between adjacent oscillators is equal and 0.2 wavelength. In simulation, the external and internal diameters are 12mm and 10 mm, respectively. And the feeding mode is capacitive coupling mode. The length of antenna oscillator can be changed. The simulating mode of the plasma antenna is shown in figure 1. The designed plasma antenna consists of an active oscillator, a passive reflecting oscillator and three passive directing oscillators, because when the number of the active oscillator is more than five, the gain variation of antenna is not very large. In order to highlight the obvious reconfigurable characteristics of the plasma antenna, only three passive directing oscillators are selected. According to formula (3), the relative dielectric constant of plasma ranges can be adjusted from - 31.7 to - 283.76. From figure 4, when the length

of each oscillator of Yagi antenna is fixed, the measured and simulated values of return loss (S_{11}) are close to each other. The simulation value is slightly higher than the measured one, and the impedance bandwidth obtained by simulation is smaller than the measured value, it may be because that certain axial and radial density gradient exists in the plasma in the antenna oscillator. From figure 5, when the density is close to 10^{17} m^{-3} , the return loss of the antenna is obviously reduced and the impedance bandwidth is widened. The measured return loss of the antenna is not much different from that of the simulation, which shows that the simulation results are more reliable and the radiation performance of the plasma antenna is better when the collision frequency is low and the electron density is high.

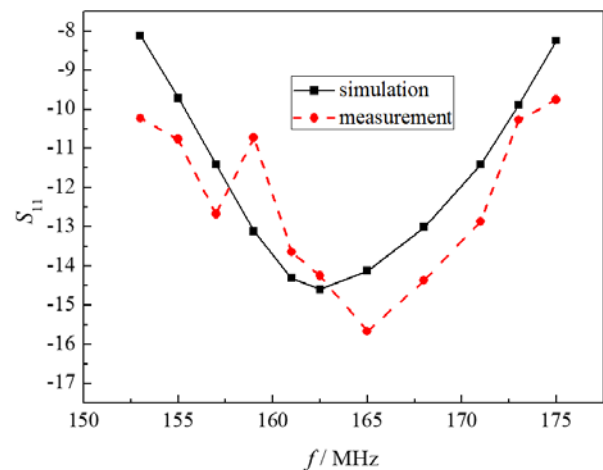

Figure 4. Antenna impedance bandwidth measurement and simulation results when the electron density is on the order of 10^{16} m^{-3}

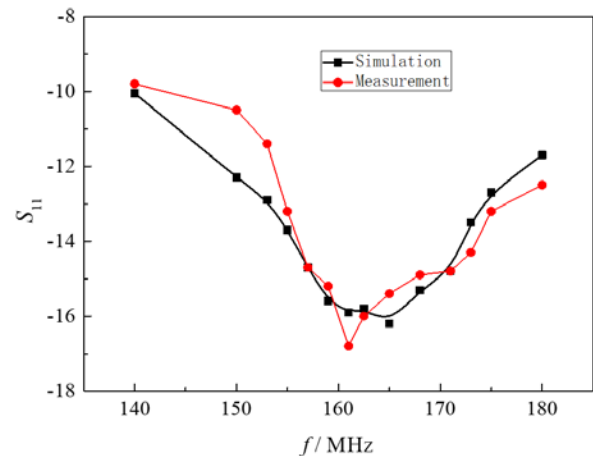

Figure 5. Antenna impedance bandwidth measurement and simulation results when the electron density is on the order of 10^{17} m^{-3} .

3.2 Radiation characteristics

3.2.1 Effect of electron density on antenna radiation characteristics

The radiation characteristics of the antenna mainly depend on the directivity and gain. The radiation characteristics and reconstruction characteristics of the plasma Yagi antenna are studied by changing the

working state of each oscillator, the distance between the oscillators and the length of the oscillators. In antenna measurements, data are measured every 10 degrees. Because any antenna measurements have uncertainty, the number of measurements for the pattern under each condition is 6 times, and then the average value is taken. Measurements and simulation results of E-plane normalized direction map of plasma Yagi antenna at 10^{17} m^{-3} electron density are shown in Fig. 6. When all the oscillators are fully open, the antenna array has good directivity, and the measured value is not much different from the simulated value. The backscatter of the measured pattern is slightly larger than the simulated value because of the reflection of the site itself.

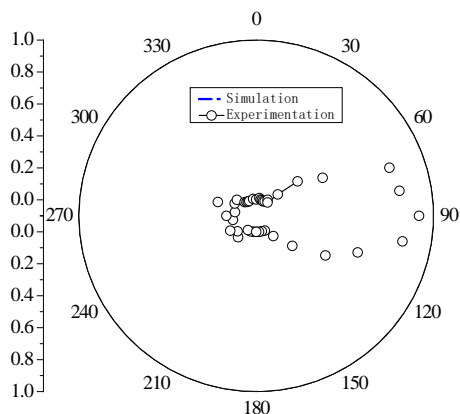

Figure 6. Plasma Yagi antenna pattern measurement and simulation results

Table 1 shows the measurement results of the decrease of half power beam width (HPBW), gain and directivity coefficient of plasma Yagi antenna under different electron densities. When the electron density is in the order of 10^{18} m^{-3} , the antenna has a high gain, approaching 7.5 dBi, and the communication coverage angle of the antenna is very small. We use HFSS software to simulate the metal Yagi antenna of the same size and size as the plasma Yagi antenna, and the gain is about 9 dBi. Hence, the gain performance of high-density plasma antenna is close to that of metal antenna. When the electron density decreases, the communication area becomes wider. When the density is 10^{17} m^{-3} , the half-power angle of the antenna approaches 60 degrees, the maximum radiation direction gains decreases to about 6 dBi, and the half-power angle approaches 70 degrees and the maximum direction gain is about 5 dBi when the electron density is about 10^{16} m^{-3} . So, the plasma Yagi antenna has very good pattern reconfigurability and can quickly construct the communication coverage area of AIS base station.

Table 1. Half-power angle and gain of the vertical plane of the antenna at different electron densities

density (m^{-3})	gain (dBi)	HPBW ($^\circ$)
10^{16}	5.07	67.5
10^{17}	6.24	59.4
10^{18}	7.41	51.7

3.2.2 Working state of the passive oscillator

When the passive oscillator is all closed and only the active oscillator is working, the antenna is a monopole antenna. At this time, the horizontal direction is omni-directional, which can realize omni-directional broadcasting of information. When the reflection oscillator is opened and the number of leading oscillators is changed, the directionality changes quickly. Figure 7 shows the simulation results of three-dimensional pattern of the plasma Yagi antenna when the passive oscillator is all closed and all opened at the signal frequency of AIS2 (162.025 MHz). When all passive dipoles are closed, the antenna is a half-wave symmetrical dipole antenna, and the horizontal direction is omnidirectional. When all passive oscillators (one reflecting oscillator and three leading oscillators) are turned on, the directivity of the antenna changes rapidly. Table 2 shows the effect of the number of leading oscillators on the main lobe HPBW of the vertical plane pattern of the plasma Yagi antenna when the electron density of the plasma is 10^{18} m^{-3} under the condition of opening a reflecting oscillator. When all the leading dipoles are closed, the half power angle of the antenna is very large. When the number of the leading dipoles is increased, the directivity of the antenna increases, the communication range narrows and the HPBW decreases. When the number of leading dipoles increases to 3, the HPBW decreases to about 65 degrees. When the number of leading dipoles increases to 5, the HPBW decreases to nearly 50 degrees. Therefore, when the plasma electron density is a constant, by changing the number of passive leading oscillators, the antenna directivity can be rapidly adjusted, and the number of leading oscillators can be increased. The front-to-back ratio in the antenna pattern increases, the directivity increases, and the half power angle narrows. Table 3 shows the experimental and simulation results of the effect of the number of leading oscillators on the maximum radiation directional gain. The electron density is 10^{17} m^{-3} , and the gain measurement method of plasma antenna is comparative method. The measured and simulated gains have little difference and the variation trend is the same. As the number of oscillators increases, the antenna gain increases. The reconfigurable range of antenna can be enlarged by synthetically changing the electronic density and the working state of antenna oscillator

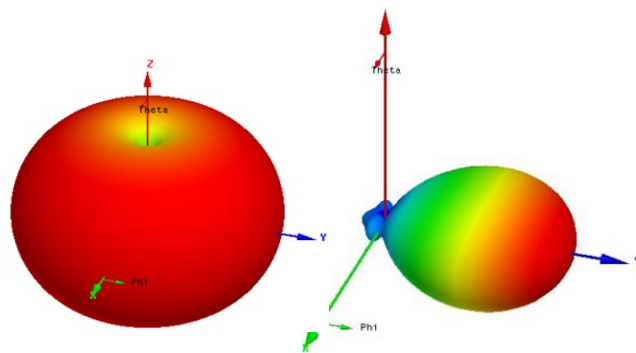

Figure 7. Three-dimensional pattern of the passive reflection of the plasma Yagi antenna and the full opening and full closing of the guiding oscillator

Table 2. Influence of the number of directors on the half power angle of the vertical plane pattern of the antenna

Number of directing oscillator	HPBW (°)
0	117.4
1	85.7
2	72.2
3	64.6
4	56.7
5	51.7

Table 3. Influence of the number of directors on the maximum gain

Number of directing oscillator	measure dBi	simulation dBi
0	2.78	3.02
1	3.57	3.82
2	4.93	5.23
3	5.34	5.58
4	5.92	6.27
5	6.23	6.56

4 FEASIBILITY ANALYSIS OF ELECTRONICALLY CONTROLLED PLASMA YAGI ANTENNA FOR AIS BASE STATION TRANSMITTING ANTENNA IN SHIPS' ROUTEING WATERS

The results of experiments combined with the simulation show that by adjusting the plasma electrical parameters, the plasma antenna system can be adjusted to match the transmission line. At the same time, by adjusting the antenna oscillator electrical parameters, the distance between the vibrators and the vibrator electrical length, the directivity and gain of the antenna can be dynamically adjusted, and also the coverage area of the antenna can be adjusted too. When only the active vibrator of the antenna system is turned on and all passive vibrators are turned off, it can be used as an omnidirectional antenna to realize AIS information broadcasting. While in order to achieve different operating frequencies, metal antennas must change the size or shape of the antenna. In the VHF communication band, only dual or triple frequency communication can be realized. In the design of the reconfigurable antenna, the plasma antenna is more convenient.

The experimental results of the absorption and reflection of electromagnetic wave by plasmons are given in the literature^[13]. When the plasma frequency is large enough, the electromagnetic wave reflection performance is enhanced. When the density of the plasma electron is increased, the reflection oscillator enhances the reflection of electromagnetic waves. On the basis of increasing the number of directors, the orientation of the antenna is enhanced and the backscattering is reduced, thereby reducing the backward electromagnetic interference of the antenna. When the antenna is not required to work, the antenna oscillator is turned off to achieve zero interference.

In terms of energy consumption, the literature^[13] gives the power required for the plasma antenna excitation source to maintain a-1m-long antenna. In the excitation mode of the kHz-level AC power

supply, the discharge power is generally less than 2W.

In addition, in the plasma antenna system, if the plasma parameter is properly adjusted, the size of the plasma discharge tube can be reduced, which can miniaturize the plasma Yagi antenna and also reduce the weight of the antenna. In this respect, there is a certain advantage over metal antennas.

Of course, the plasma antenna has a certain gap in terms of antenna gain and electromagnetic compatibility. At present, both the MHz-level AC and kHz-level AC plasma excitation sources can generate higher-density plasmas, and the advanced filtering technology and shielding technology can greatly reduce electromagnetic interference. Therefore, in the near future, the plasma antenna can be applied to the field of maritime communication, and in particular, it can significantly improve the communication effect and maritime supervision capability of the ship's routeing waters.

5 CONCLUSION

Through the simulation and experimental study of the plasma Yagi antenna model and the feasibility analysis of the plasma antenna used in AIS base station transmitting antenna within ships' routeing waters above-mentioned, it is concluded that:

- 1 By changing the plasma electron density, the number of reflected vibrators, the number of directors and the working state, the antenna parameters such as directivity, gain and input impedance of the antenna can be dynamically adjusted to achieve fast and dynamic adjustment of the plasma antenna. Thus, the plasma Yagi antenna can be used as a smart antenna.
- 2 The plasma Yagi antenna can achieve impedance matching by adjusting the plasma state without applying any matching network at the AIS communication band.
- 3 Plasma Yagi antenna can be improved in terms of power consumption, electromagnetic compatibility, gain, reconfigurability, etc., and meet the communication requirements of AIS base station transmitting antennas. As a consequence, It can be used as the transmitting antenna of AIS base station in ships' routeing waters.

REFERENCES

- [1] Huang C H, Xiao Y J, Gao D Y et al. Evaluation model of navigation risk in routeing waters and its application [J]. China Safety Science Journal, 2014, 24(2): 93-99.
- [2] Liu Y H, Xiao Y J, Guan K P. Ships' Routeing for Ningbo-Zhoushan core harbor area based on marine traffic investigation of AIS [J]. Journal of Shanghai Maritime University, 2014, 35(1): 1-5.
- [3] Zhao H C, Liu S B, Kong X K et al. Simulation and experimental study on the plasma Yagi antenna [J]. Journal of Microwaves, 2014, 30(1): 20-23.
- [4] Rayner J P, Whichello A P, Cheetham A D. Physical Characteristics of Plasma Antennas. IEEE Transactions on Plasma Science, 2004, 32(1): 269-281.

- [5] Huang F Y, Shi J M, Yuan Z C, et al. Theoretical and experimental study of plasma directional antenna array [J]. *Acta. Phys. Sin.*, 2013, 62 (15): 155201-1-155201-7.
- [6] Belyaev B. A., Leksikov A. A., Leksikov A. A. et al. Nonlinear Behavior of Plasma Antenna Vibrator [J]. *IEEE Trans. Plasma Sci.*, 2014, 42 (6): 1552-1559.
- [7] Liang Z W, Zhao G W, Xu J, et al. Analysis of Plasma-column antenna using moment method [J]. *Chinese Journal of Radio Science*, 2008, 23(4): 749-753.
- [8] Yuan Z C, Shi J M, Yu G F, Principles and realization of surface wave driven plasma antenna [J]. *Electronic information countermeasure technology*, 2006, 21(4): 38-41.
- [9] Song Z, Zhang J H, Huang Y. *Antenna and Propagation* (The second edition). Xidian University Press:2011.
- [10] Kraus J D *Antenna* (The third edition), Electronic industry press: 2006.
- [11] Zhang Z T, Zhao J S, Xu X W et al. Experimental Study on the Interaction of Electromagnetic Waves and Glow Plasma. *Plasma Science and Technology*, 2011, 13 (3): 279-285.
- [12] Zhao J S, Zhang Z T, Wang J, et al. A U-shape plasma antenna based on excitation of 5-20 kHz alternating current power supply [J]. *Acta. Phys. Sin.*, 2012, 61 (19): 301-307.
- [13] Zhao J S, Sun Y, Ni Y W, et al. Light-electricity method for measuring switch-on time of plasma antennas [J]. *High Power Laser and Particle Beams*, 2017, 29 (5): 1-7.
- [14] Zhao J S, Chen Y L, Sun Y, Wu H F, Liu Y, et al. Plasma antennas driven by 5-20kHz AC power supply [J]. *AIP Advances* 5, 2015, 127114.