

Ground-based, Hyperbolic Radiolocation System with Spread Spectrum Signal - AEGIR

S.J. Ambroziak, R.J. Katulski, J. Sadowski, W. Siwicki & J. Stefanski
Gdansk University of Technology, Poland

ABSTRACT: At present the most popular radiolocation system in the world is Global Positioning System (GPS). As it is managed by the Department of Defence of the U.S.A., there is always the risk of the occasional inaccuracies or deliberate insertion of errors, therefore this system can not be used by secret services or armies of countries other than the U.S.A. This situation has engendered a need for development of an autonomous, ground-based radiolocation system, based on the hyperbolic system with spread spectrum signals. This article describes the construction and operation of such a system technology demonstrator which was developed at the Technical University of Gdansk. It was named AEGIR (god of the ocean in Norse mythology). This paper presents preliminary results and analysis of its effectiveness.

1 ASSUMPTIONS OF DESIGNED SYSTEM

The starting point is to build a ground-based system which is mainly associated with the hyperbolic localization systems. They are based on the differential measurement method called Time Differential of Arrival (TDOA). The first hyperbolic system (Gee) appeared during Second World War. It has evolved (DECCA, OMEGA), but the moment satellite navigation appeared, they have practically gone out of use. Up to now only LORAN C system is still operational.

Our goal has been to create a system of hyperbolic localization but made in modern technology. The designed system uses spread spectrum signals. The second element is an asynchronous operation. The system resigns chain relationship between stations. With this approach, our system has gained new features and new functionality compared to traditional solutions.

The first task is to determine the basic parameters, i.e.: frequency, bandwidth, modulation, etc. After careful consideration, the following parameters have been set:

- spread spectrum signals (using DS-CDMA)
- reliance on a hyperbolic system (TDOA method)

- frequency: 431.5 MHz
- the width of the transmission channel – 1 MHz
- transmission speed of navigational information - 1 kb/s.
- modulation: QPSK

2 HYPERBOLIC SYSTEMS – TDOA METHOD

The TDOA method, as mentioned before, is based on a calculation of the time difference between stations. Suppose there are N ground stations, the coordinates for the i-th station are $S_i = (x_{Si}, y_{Si})$, where $i = 1, \dots, N$, and the search object's coordinates are $M = (x_M, y_M)$.

If you define a signal propagation time between the i-th station and the searched position in the point M as T_i , so the distance between the i-th station and the point M is as follow:

$$d_i = T_i \cdot c = \sqrt{(x_{Si} - x_M)^2 + (y_{Si} - y_M)^2}, \quad (1)$$

where:

c - velocity of wave propagation ($3 \cdot 10^8$ m / s)

T_i - the propagation delay between the i -th station and the point M,

d_i - distance between i -th station and the point M.

Timing differences between the i -th station and a first one, can be written as:

$$T_{i1} = T_i - T_1 \quad (2)$$

Differences in the distances between those stations, can be described by the following relationship:

$$d_{i1} = T_{i1} \cdot c = d_i - d_1, \quad (3)$$

After putting equation (1) in equation (3) we obtain hyperbolic equation:

$$d_{i1} = \sqrt{(x_{s_i} - x_M)^2 + (y_{s_i} - y_M)^2} - \sqrt{(x_{s_1} - x_M)^2 + (y_{s_1} - y_M)^2}. \quad (4)$$

Equation 4 presents the difference in distance between the first and i -th station.

Determination of the distance difference between another pair of base stations generates more hyperbolas and a point of their intersection gives us a position. There are many algorithms [1-4], which allow to determine the coordinates, however for the purpose of the system the Chan method was chosen [1].

The principle of TDOA method can be illustrated as follows. Assume that we have three reference stations positioned as in Figure 1.

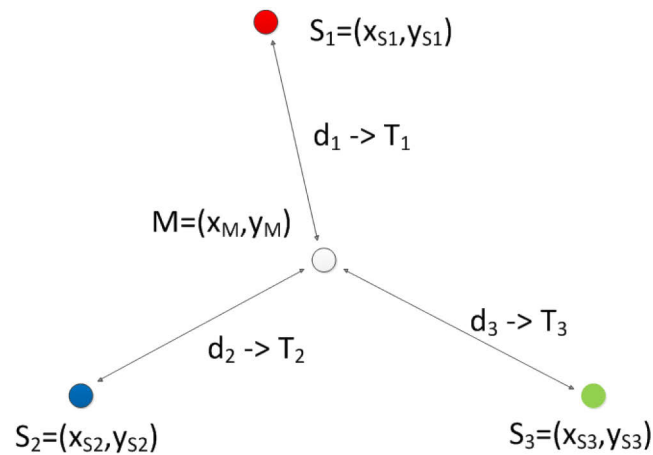

Figure 1. Deployment of ground stations to illustrate the method of TDOA

Propagation time from the station to your desired position in the point M is respectively T_1 , T_2 and T_3 and the distance between them is d_1 , d_2 and d_3 . Each station has coordinates as follows: $S1=(x_{S1}, y_{S1})$, $S2=(x_{S2}, y_{S2})$ and $S3=(x_{S3}, y_{S3})$.

Determination of temporary differences between the stations is illustrated in Figure 2. It has been

assumed that each station transmits at the same time an impulse signal. Figure 2a shows the moment of broadcasting signals by the station. Figure 2b shows the time of receipt of the impulses at the point of searched position.

Analyzing Figure 2 it can be observed that when the impulses are transmitted at the same time from each ground station, the time difference at the receiver side is easily measured. Unfortunately, such a synchronization is difficult to obtain.

For this reason, the system has been designed as asynchronous one. This allows switching off and on any station without resynchronization the system. In order to implement this feature, it has been necessary to create a reference station, which not only transmits, but is also able to receive signals from neighbouring stations. With this approach, the reference station measures the time differences in synchronization between the reference signal and its neighbouring stations so the calculated time differences are sent to the receiver. This mode of operation is illustrated in Figure 3 [8].

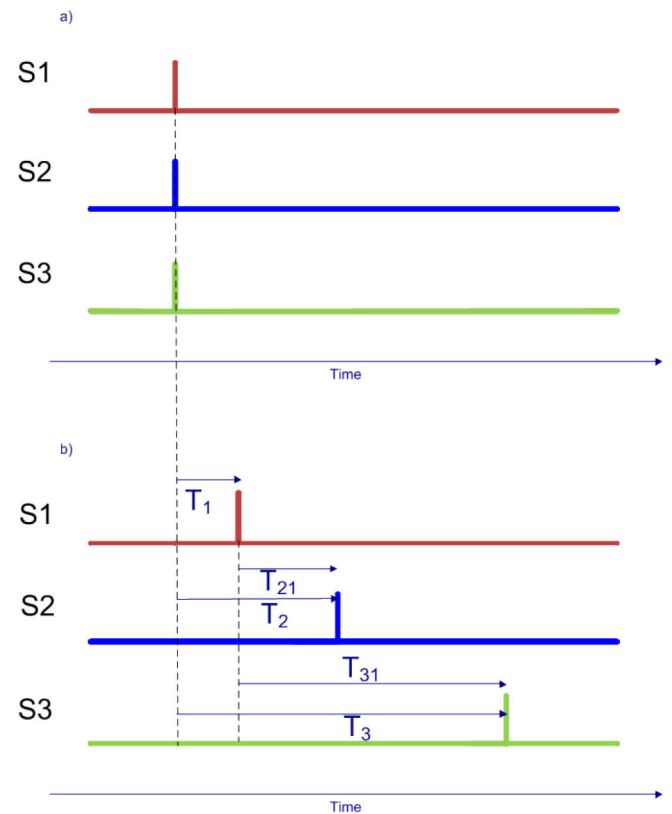

Figure 2. Timing between signals broadcasted by ground stations a) the moment of broadcasting impulses by the stations b) the time of receipt of impulses by the receiver

As in the previous example, stations transmit a reference signal as an impulse, but time of broadcasting these impulses, as shown in Figure 3, is random. The stations have the ability to "listen to" neighbouring stations. This is illustrated in Figure 3b. Reference station designated as S1 receives signal from other two stations: S2 and S3, and

calculates the time difference between its own and these stations' signals (nT_{21} and nT_{31}). These time differences are then sent to the receiver. The receiver (pictured in Figure 3c) sets its own time difference between the received impulses from the reference station (dT_{21} and dT_{31}). Additionally, each ground station sends to the receiver its own coordinates (respectively x_{S1} , y_{S1} - the coordinates of the first station, x_{S2} , y_{S2} - coordinates of the second station and x_{S3} , y_{S3} - coordinates of the third station), so that the receiver calculates the propagation time between the reference stations (T_{S1S2} , T_{S1S3}). Taking into account all sent data, the receiver calculates a real difference in propagation time between stations, which present the following equation:

$$\begin{aligned} T_{21} &= nT_{21} - dT_{21} - T_{S1S2} \\ T_{31} &= nT_{31} - dT_{31} - T_{S1S3} \end{aligned} \quad (5)$$

The time differences defined in this manner allow to determine coordinates of searched object M using one of the sets of algorithms [1-4].

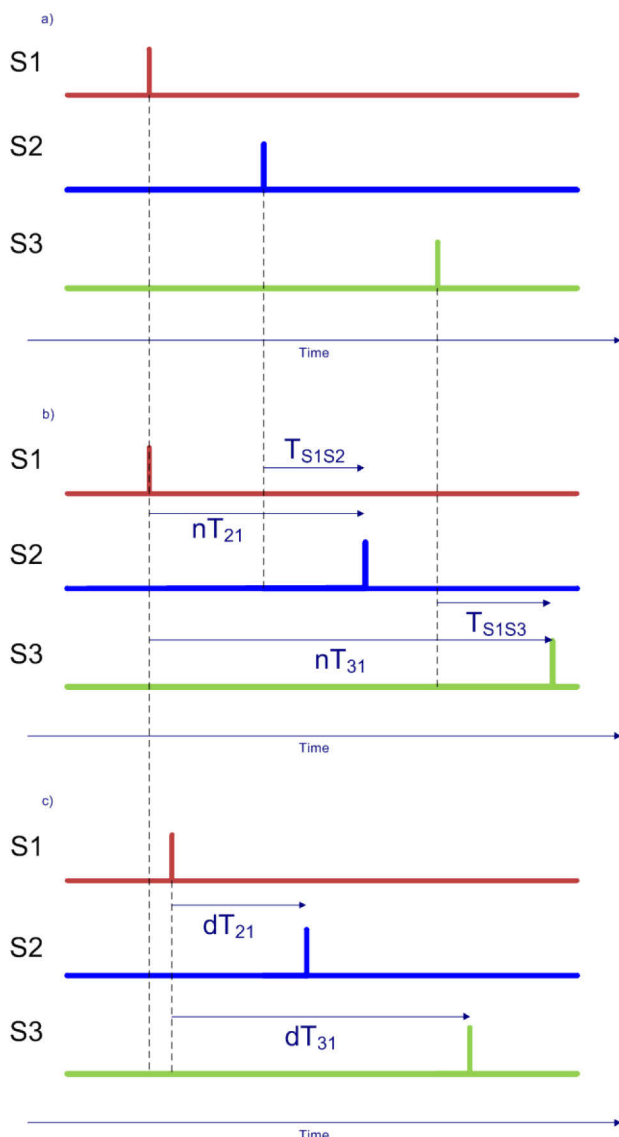

Figure 3. Timing between signals broadcasted by base stations in an asynchronous system, a) the moment of broadcasting

impulses by the stations b) the time of receipt of impulses by S1 station c) the time of receipt of impulses by the receiver [8]

In case of reception from only three stations, Chan's algorithm will result in a set of two coordinate values. Only one of them is correct and the other one lies outside the presented area [7].

3 HARDWARE IMPLEMENTATION

The system consists of a localizer/receiver and ground/reference stations.

The block diagram of a receiver is presented in Figure 4.

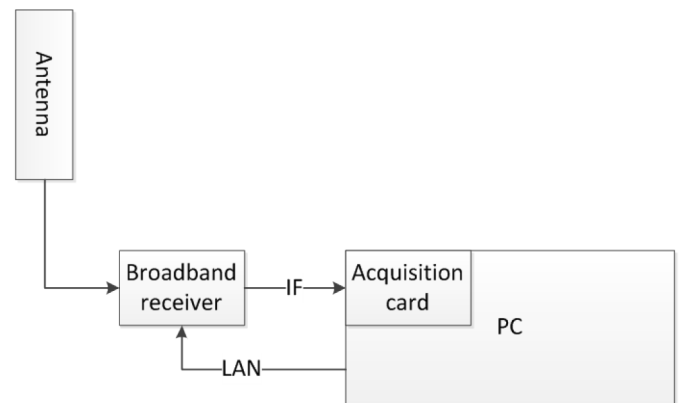

Figure 4. Block diagram of a receiver

The receiver has been made in the technology of Software Defined Radio [5]. It consists of: an antenna, a broadband receiver, an analog to digital converter (in the form of data acquisition card) and digital signal processor (in form of PC). This approach allows to shape flexibly functionality of the receiver. Hardware implementation of a receiver is presented in Figure 5.



Figure 5. Hardware implementation of the receiver

Ground stations, as it was mentioned before, have the ability to "listen to" neighbouring stations. It is assumed that the system should consist only of such stations (Master ones). However for demonstrable purposes only one Master station is required. Therefore two types of ground stations were created: broadcasting stations (Slave type) and broadcasting and listening ones (Master type).

The block diagram of a Slave station is shown in Figure 6.

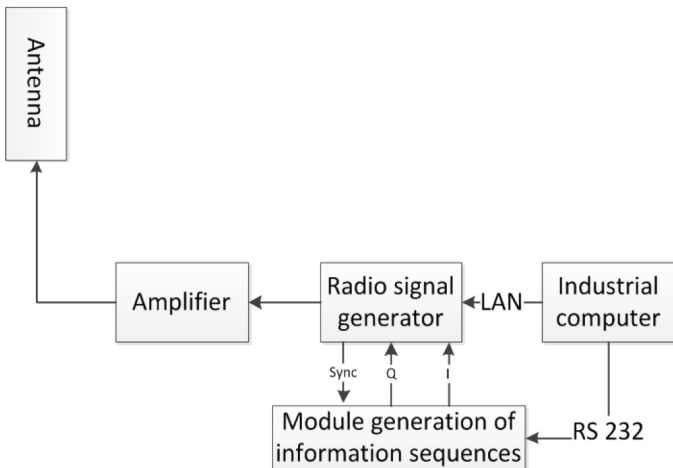

Figure 6. Block diagram of a Slave station

The main element of the station is a radio signal generator, whose task is to broadcast modulated signal with data that are generated by industrial computer. Hardware implementation of a Slave station is shown in Figure 7.



Figure 7. Hardware implementation of a Slave station

The block diagram of the last element of the described system - Master station – is shown in Figure 8.

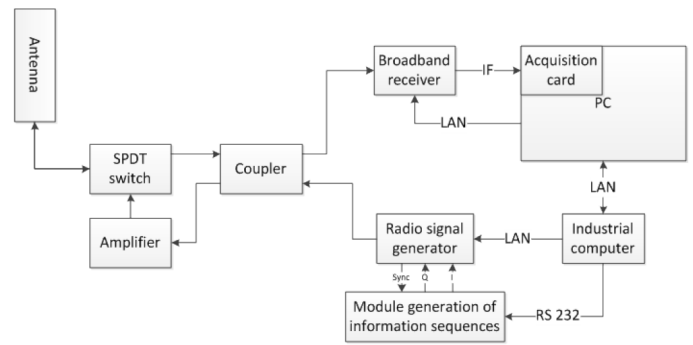

Figure 8. Block diagram of a Master station

Master station is a combination of a receiver and a Slave station. The task of the receiver is to listen to a nearby station and to determine difference in synchronization between reference signal and signals from the neighbouring stations. Hardware implementation of a Master station is shown in Figure 9.



Figure 9. Hardware implementation of a Master station

As already mentioned, the system uses spread spectrum signals. Broadcasted signals are called Navigation Messages and they are divided into two types. First type – called Basic Navigation Message (BNM), contains information of geographic coordinates of reference station, the height of the suspension of the antenna, transmitter power, etc. The second one – Additional Navigation Message (ANM) – contains previously mentioned time differences between stations.

4 TESTS AND RESULTS

The developed technology demonstrator was tested twice in real conditions. The area of our tests was the Bay of Gdansk. The first measurements were carried out in April 2010. with the three ground

stations located: first - on top of the CTM building, second – on the top of the lighthouse in Hel and third – on the top of the lighthouse in New Port. The receiver was placed on a small watercraft. Those tests allowed us to find the underdeveloped parts of the system and suggested new approaches. Subsequent measurements were carried out six months later, in October 2010. For the purpose of these tests, the fourth reference station (Slave one) was added; it was installed on the top of the building of the Faculty of Electronics, Telecommunications and Informatics of Gdansk University of Technology (positions of all four ground stations are presented in Figure 10).

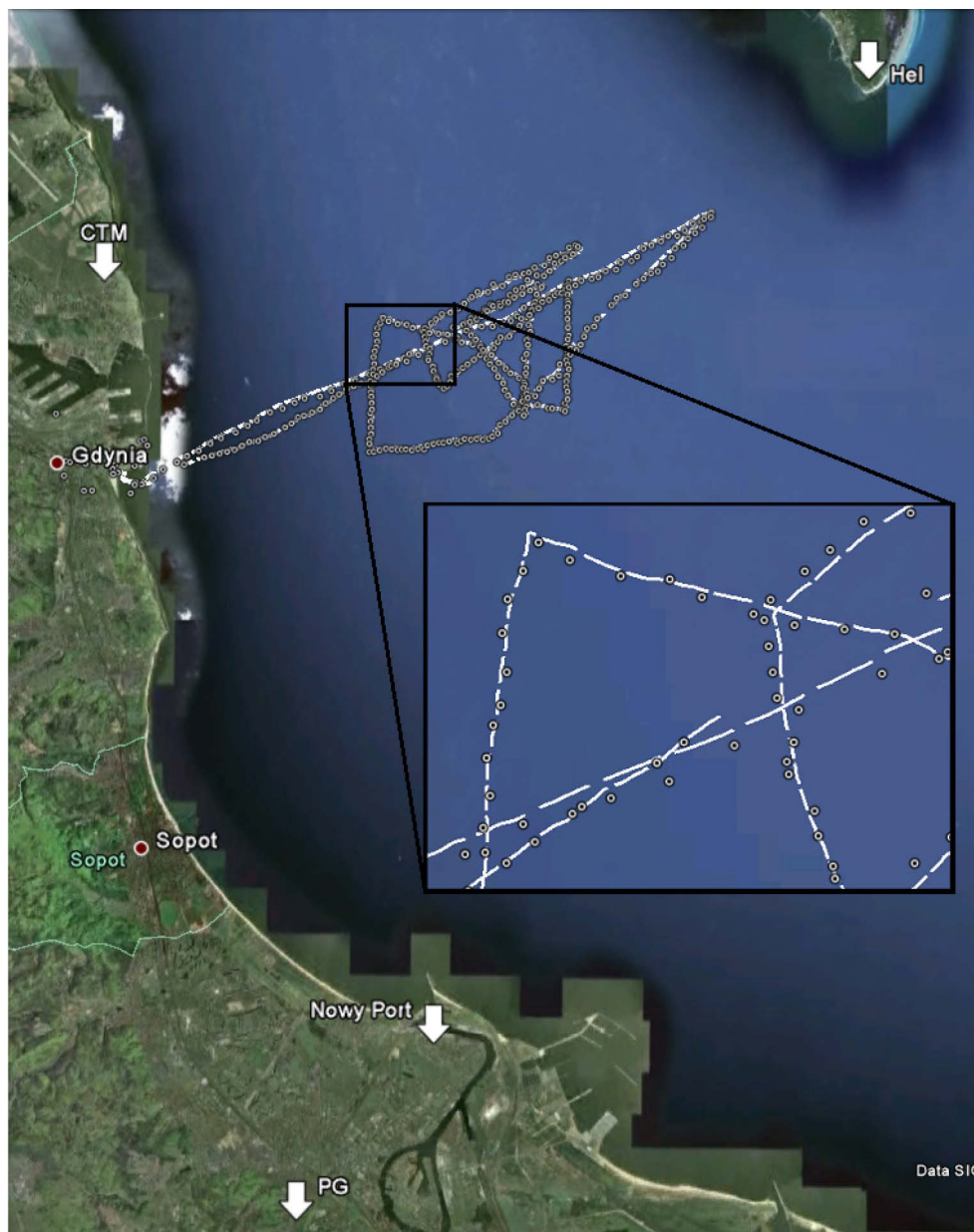

Figure 10. Deployment of four ground stations (arrows) and a path of GPS and GLONASS positions (dotted line) and readings of autonomous AEGIR system (dots)

During field tests a position from a satellite navigation system was recorded with the use of a Javad Alpha receiver, which enables simultaneous reception from both American (GPS) and Russian (GLONASS) systems.

The effects of our tests are illustrated by the visualization shown in Figure 10, created with use of Google Earth software. The dotted line represents the path of positions received from the satellite systems GPS/GLONASS, and the dots represent the calculated positions of the ground-based system. Analyzing the visualization shown in Figure 10 it can be observed how accurate the route travelled by the vessel was reconstructed by points calculated by the autonomous localization system - AEGIR.

5 CONCLUSIONS

The presented results are the preliminary approach to the analysis of a designed system. The first results suggest that this solution can be very useful for military purposes.

The presented system has been developed to be very flexible. It allows to use more than three ground-stations. Placing them in areas of known positions, allows to create a grid, which will provide an independent reading of coordinates from satellite systems.

The presented system is fully asynchronous. In case of damage or shutdown of one of the stations, the system in a short time will be again fully functional. The only condition is to receive signals from at least three ground stations.

ACKNOWLEDGEMENT

The described research is funded by the Polish Ministry of Science and Higher Education as a part of research and development project No O R00 0049 06. The authors express their sincere thanks for allocated funds for this purpose.

REFERENCES

- [1] Chan Y.T., Ho K.C., "A Simple and Efficient Estimator for Hiperbolic Location", IEEE Transactions on signal processing, pp. 1905-1915, vol. 42, no. 8, August 1994,
- [2] Foy W.H., "Position-Location Solutions by Taylor-Series Estimation", IEEE Trans. On Aero. And Elec. Systems, vol. AES-12, no. 2, 1976, pp. 187-194.
- [3] Fang B.T., "Simple Solution for Hiperbolic and Related Position Fixes", IEEE Trans. On Aero. And Elec. Systems, vol 26, no. 5, 1990, pp. 748-753.
- [4] Friedlander, "A Passive Localization Algorithm and Its Accuracy Analysis", IEEE Jour. Of Oceanic Engineer., vol. OE-12, no. 1, 1987, pp. 234-245.
- [5] Katulski R., Marczak. A., and Stefański J.; „Software Radio Technology” (in polish), Telecommunication review and telecommunication news No. 10/2004, pp. 402-406.
- [6] Ambroziak S.J., Katulski R.J., Sadowski J., Siwicki W., Stefański J., "Autonomous ground-based and self-organized radiolocation systems" (in polish), Naval Armament & Technology Conference NATCon'2010, Gdynia 20-21.X.2010.
- [7] Stefański J. "Methods' analysis for position estimation of movable terminal in a multipath environment" (in polish), KKRRiT 2009, Telecommunication review and telecommunication news No. 6/2009, pp.364-367.
- [8] Patent application no. P393181, "Asynchronous system and method for determining position of persons and/or objects" (in polish), 2010-12-08.