

Galileo Satellite Navigation System Receiver Concept

M. Lemanczyk & J. Demkowicz
Gdansk University of Technology, Poland

ABSTRACT: The paper presents the Galileo Satellite Navigation System's Receiver concept. The receiving path and the model of GNSS receiver system for the L1 signal was shown as well as Galileo services and frequencies were presented.

1 INTRODUCTION

Development of services connected with the Global Navigation Satellite System, depends directly or indirectly, on the progress in such areas as:

- GPS systems, EGNOS, Galileo, GPS III
- wireless telecommunication systems GSM (SMS, GPRS), UMTS, WiMax
- GIS systems (digital maps, navigation maps, thematic maps, 3D maps)
- terminals (smart phones, PDA, mobile phones)

as well as overall of standardization, certification, and licensing.

Within the next few years most of the mobile phones will be equipped with the satellite navigation systems, both GPS and Galileo. There will be revolution on the telecommunication market, when the Galileo system will be combined with the GSM and UMTS systems, providing communication and positioning with an unprecedenced accuracy.

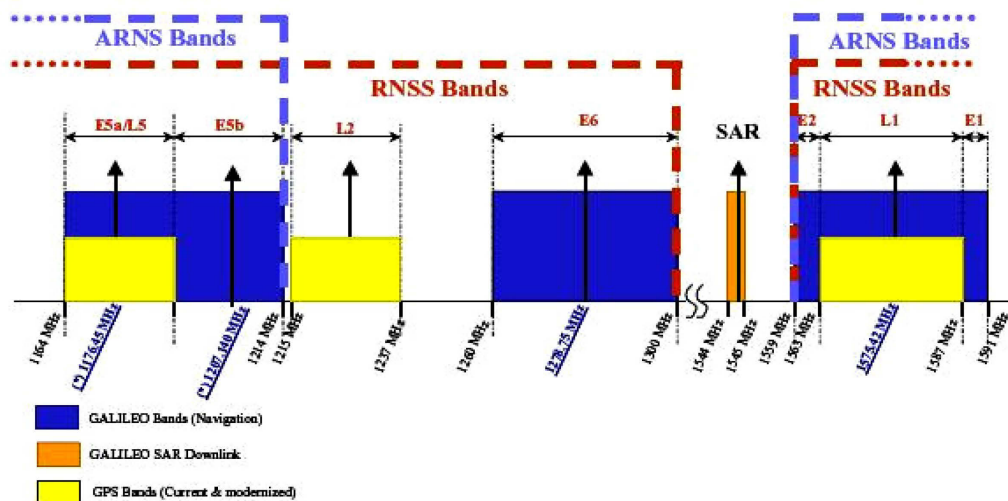

Fig. 1. Galileo signals frequency spectrum [GERAN]

At the next stage, when the whole three systems become fully functional and available: Galileo, GPS and most probable GLONASS, there will be a significant improvement in providing the signal inside the buildings, better accuracy, as well as shorter time required for collecting all the needed signals from the space. This will be the impulse for new applications to develop, which will be only limited by the law and privacy policy protection. GNSS receiver is one of the GNSS segments, but is the one that is accessible to the user. That's why research and development, connected with such a devices can be made independently in the R&D Centers, around the world. The main aim of the researches is to build the fully integrated GNSS system receiver.

2 GALILEO AND GPS SYSTEMS

Galileo and GPS are the systems that will not interfere with each other but which should cooperate. One of the establishment of the Galileo constructor engineers was to use such a signals that they could be received on the Earth, on such a terrain, as forest and high-density housing, but even though the signal should not interfere with the GPS signal. The same CDMA (*Code Division Multiple Access*) modulation scheme is used in the E5a and E2-L1-E1 Galileo signals, as well as the same carrier frequencies that the GPS signals are with. Fig. 1. The same carrier frequencies are used to simplify the single common receiver construction. [Hein et al.] That is why the integration of both systems will be easier and the cost of this process will be minimized.

At the each moment of time the L1 C/A code of the GPS signal do not interfere the Galileo BOC(2,2) signals more than 0,2 dB, witch his show in the Fig.2. L1 Galileo signal has the right hand polarization, carrier frequency of 1575,42 MHz and the 40,92 MHz band. The signal is divided into L1A (used for PRS services), L1B and L1C channels. The L1B signal is the data channel. It is generated using the modulo 2 of the signal that has the navigation data and the PRN code sequence. The L1C is the pilot signal. It is generated using the modulo of the signal with the PRN code sequence and the carrier frequency. The L1B signal code has 4092 chips and L1C signal has 4092 chips and additionally 25 chips. The minimum signal power required to a proper receive the L1 (B+C) signals from the Earth is 167 dBW.

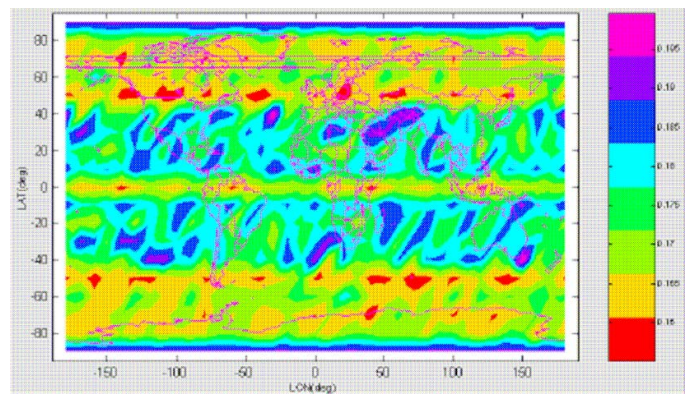

Figure 2. Maximum GPS C/A code C/N degradation in [dB] due to inter-system interference from a Galileo BOC(2,2) for L1. [Hein et al.]

The Fig. 2. shows the maximum interference ratio for the L1 signals for GPS C/A and Galileo BOC(2,2) depending on the geographical location.

Table 1. Maximal level of interference between GPS and Galileo signals [Hein et al.]

frequency band	GPS induced interference on Galileo	Galileo induced interference on GPS
L1	0.03 dB/0.09 dB	0.05 dB/0.2 dB
E5a/L5	0.5 dB/0.8 dB	0.2 dB/0.4 dB

As show in the Table 1, the values are accepted and the Galileo and GPS signals will not interfere with each other. The issue is essential because of the integration of both systems in a unified receiver. So, for the single end-user, cooperation between Galileo and GPS will mean greater accuracy, availability and certainty.

From the final users perspective the Galileo satellite navigation system will be conducted through the five available services, that is:

- 1 Open Service - *OS* – available without payments, for all users (naturally with lower accuracy), compatible with the GPS SPS (*Standard Positioning Service*)
- 2 Commercial Service - *CS* – available for a charge, for certain users (with greater than OS, guaranteed! accuracy)
- 3 Safety of Live - *SoL* – available without payment, for all users, with guaranty of action, (Quality Of Service)
- 4 Public Regulated Service - *PRS* – available without payment, for certain users – members of Galileo Project, controlled by them, with a strategic meaning (i.e. Military Defense Systems)
- 5 Search and Rescue - *SAR* – available for all users, enabling to send reflexive message to the rescue station

To accomplish these requirements Galileo uses 10 signals in 4 bands, namely E5a (1 and 2), E5b (3 and 4), E6P (5), E6C (6 and 7), L1P (8) i L1F (9 ad 10). Some publications mention only 6 signals are broadcasted (E5a, E5b, E6P, E6C, L1P and L1F). The difference comes from the fact that signals are transmitted at the same frequency, one is called data channel (contains datas) and the second is a pilot channel (contains the pseudo code).

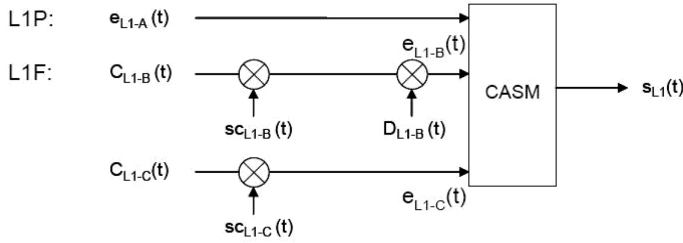

Figure 3. The L1 signal simplified modulation scheme [GERAN]

The L1 signal is used in such a services like: Open Service (OS), Safety if Live (SoL), Commercial Service (CS) and in Public Regulated Service (PRS). The E6 signal will be used in Commercial Service (CS) and Public Regulated Service (PRS). The E5 signal will be available in Open Service (OS), Safety of Live (SoL) and Commercial Service (CS). The L1 signal depending on the usage will hald the BOC(1,1) modulation scheme (Binary Offset Carrier) or the BOC(15; 2,5). The carrier frequency will be 1575,42 Mhz and the L1 signal involves signals with the numbers 8, 9 and 10. The E5 signal will involve signals with numbers 1, 2, 3 and 4. For signals numbered as 1 and 2 the carrier frequency is 1176,45 Mhz, and the modulation scheme is AltBOC (15,10). The E5 signals with numbered 3 and 4 use the carrier frequency 1207,14 (the modulation remains the same). The E6 signals involves signals with numbered 5, 6 and 7. Their carrier frequency is 1278,75 Mhz, for signal number 5 the modulation scheme is the BOC(10,5), but for the signal numbers 6 and 7 it is BPSK-R5 modulation scheme.

3 GALILEO SYSTEM RECEIVER

3.1 Galileo transmitting path

The signal in the transmitting path for the L1 signal for channels B and C has the following scheme (see eq. 1).

$$e_{L1-B}(t) = \sum_{F=-\infty}^{+\infty} \left[c_{L1-B} |d_{L1-B}| d_{DC-L1-B} \text{rect}_{T_{c,L1-B}}(t - iT_{c,L1-B}) \text{sign}[\sin(2\pi R_{s,L1-B}t)] \right]$$

$$e_{L1-C}(t) = \sum_{F=-\infty}^{+\infty} \left[c_{L1-C} |d_{L1-C}| \text{rect}_{T_{c,L1-C}}(t - iT_{c,L1-C}) \text{sign}[\sin(2\pi R_{s,L1-C}t)] \right]$$
(1)

Because of the CASM (*Coherent Adaptive Subcarrier Modulation*) modulation scheme, which assures the stable power level transmitted from the satellite. The common signal for the L1 frequency is shown with the following theorem:

$$s_{L1}(t) = \frac{1}{3} \left\{ \begin{aligned} & \left[\sqrt{2}e_{L1-B}(t) - \sqrt{2}e_{L1-C}(t) \right] \cos(2\pi f_x t) + \\ & \left[2e_{L1-A}(t) + e_{L1-B}(t)e_{L1-C}(t) \right] \sin(2\pi f_x t) \end{aligned} \right\}$$

where:

f_x	Carrier Frequency [Hz]
l_{x-y}	Ranging Code Repetition Period [Chips]
$T_{c,x-y}$	Range Code-Chip-Length [Seconds]
$T_{s,x-y}$	Subcarrier-Period [Seconds]
$R_{c,x-y}$	$1/T_{c,x-y}$; Code-Chip-Rate [Hz]
$R_{s,x-y}$	$1/T_{s,x-y}$; Subcarrier-Frequency [Hz]
$R_{D,x-y}$	$1/T_{D,x-y}$; Binary (NRZ modulated) navigation message signal
$c_{x-y(t)}$	Binary (NRZ modulated) ranging code
$d_{x-y(t)}$	Binary (NRZ modulated) navigation message signal
$sc_{x-y(t)}$	Binary (NRZ modulated) subcarrier
$e_{x-y(t)}$	Binary NRZ modulated navigation signal component including code, sub-carrier (if available) and navigation message data (if available); $(c_{x-y(t)} \cdot sc_{xy(t)} \cdot d_{x-y(t)})$;
$s_x(t)$	Normalised Baseband Signal (= $s_X-I(t) + js_X-Q(t)$)
$ i _L$	'i' modulo L

3.2 Galileo receiving path

Finally the Galileo receiving path for the L1 frequency includes the NCO generator, *I-Q* demodulator, pilot signal correlator and the correlator for the data channel, as shown in the Fig.4.

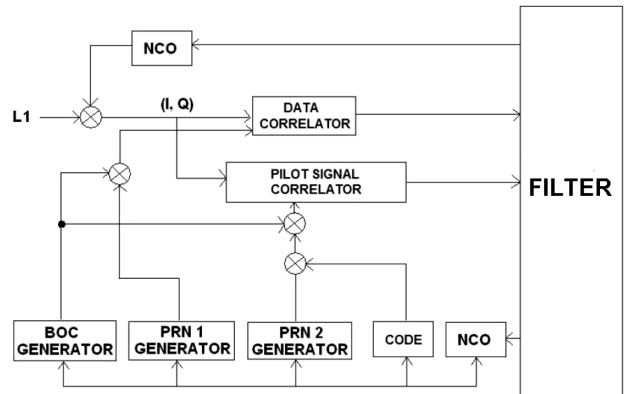

Figure 4. Galileo receiver block diagram

The Gold codes in the correlator has 4092 bits. The process of the canvassing will be relatively long and first to run should be for the piloting signal, the second step should be for the channel with the datas. The filtration block should be responsible both for signal demodulation and for the BOC phase sequence setting (*Binary Offset Carrier*), as well as for receive signal frequency.

4 CONCLUSIONS

The paper presents a few essential concepts on the Galileo satellite navigation system and especially the Galileo receiver. The receiver is a project undergone in the Dep. of Geoinformatics of Gdansk University of Technology. Unfortunately some of the Galileo concepts are still verified and the first stage of building the system is to be closed in the 2008 and

that is that time the Galileo concepts could be verified and some of the parameters can be modified or changed. Therefore the main short-time project goal include postprocessing and testing procedure using software simulator and raw GPS/Galileo signal record.

REFERENCES

- 3GPP TSG GERAN, 2005 meeting: *L1 band part of Galileo Signal In Space ICD (SIS ICD)*, Galileo Joint Undertaking, Quebec, Canada.
- Guenter W. Hein, Jeremie Godet, Jean-Luc Issler, Jean-Christophe Martin, Philippe Erhard, Rafael Lucas-Rodriguez and Tony Pratt, 2002 *Status of Galileo Frequency and Signal Design*, Galileo Signal Task Force, European Commission, Brussels.