

# Clarification, Systematization and General Classification of Electronic Chart Systems and Electronic Navigational Charts Used in Marine Navigation. Part 1 - Electronic Chart Systems

A. Weintrit

*Gdynia Maritime University, Gdynia, Poland  
Poland Branch of the Nautical Institute, UK*

**ABSTRACT:** In the paper, the author attempts to isolate, clarify, systematize, and classify various types, models and kinds of electronic chart systems, operating nowadays on the shipping market, which are a perfect example of the use of GIS (Geographic Information System) technology in widely comprehended maritime and inland waterway applications, in particular tries to promote internationally standardized system ECDIS (Electronic Chart Display and Information System), its RCDS mode (Raster Chart Display System), as well as Warship ECDIS (WECDIS), and Inland ECDIS (I-ECDIS). In the paper the author presents the general classification of electronic chart systems taking into consideration the following criteria: international standards, certification by classification society, used data base, updating system and certification by maritime administration.

## 1 INTRODUCTION

The maritime world achieved another milestone in July 2018, when the schedule for transitioning SOLAS-class ships to Electronic Chart Display and Information Systems (ECDIS) using Electronic Navigational Charts (ENCs) was complete. This is a great opportunity to summarize these several dozen years of intense work of visionaries, enthusiasts, and experts, who have brought the idea of electronic maps to the end, that is, to the full implementation and replacement of traditional paper charts on ships. Most national Hydrographic Offices (HOs) have full suites of ENCs, and transitioned internal workflows to maintain ENCs first, ensuring they are up to date with the latest information [Smith, 2018]. But is it really true? [Weintrit, 2018].

In last thirty years information technology has significantly changed the concept of navigation mainly through the introduction of the latest computers and communication capabilities that

facilitate communication with seagoing vessels [Weintrit, 2001, 2009]. Networking shipowners, vessel traffic service centres, river information systems, and individual vessels in ocean, coastal, offshore and inland navigation is carried out with the latest state of-the-art technology in computers and efficient communication network systems and e-Navigation [Patraiko et al., 2010; Hagen, 2017]. Official electronic navigational charts (ENCs) are based on the relevant hydrographic office's source data or official charts, and are compiled, coded and regularly updated in accordance with international standards. The value of the electronic chart's development is not in simply imitating the paper nautical chart, but in providing a dynamic display which successfully combines the real-time location of the ship with radar/ARPA/AIS returns and chart information. To maintain the visual simplicity of this more complex display, the data format, organization and type of chart features shown, and the way they appear on the screen, must reflect the relative importance of the information to safe navigation. Unlike the static paper chart, the

electronic chart can change the display and emphasis of symbols, based on actual real-time events and the viewing scale chosen. The computer-based algorithms of the electronic chart allow it to always include the least number of symbols which are most relevant to a given situation and for a specific user. This article attempts to systematize and classify different types, models and kinds of electronic chart systems which exist on the market and are used in marine navigation, their specificity, operational status, significance and the role they play.

## 2 ELECTRONIC CHART DISPLAY AND INFORMATION SYSTEM (ECDIS)

The basic navigational equipment required today on board a ship depends on the size of the ship, and the rules include provisions for backup system and alternates. Regulation 19 of Chapter V of Safety of Life at Sea (SOLAS) Convention states that all ships (on international voyages) must carry charts suitable for the intended voyage, which can be an ECDIS, as well as a navigation system receiver such as a GPS [Hagen, 2017; Weintrit, 2015].

As goes with all cases, firstly, it is important to identify the risks and not to show over-reliance on this new technology. For that purpose, a close look to the system itself is required. Industry stakeholders have discussed a lot about the pros and cons of paperless navigation concluding that ECDIS does have an edge over the traditional paper chart navigation [Edmonds, 2007].

The primary function of the ECDIS is to contribute to safe navigation. ECDIS with adequate back-up arrangements may be accepted as complying with the up-to-date charts required by regulations V/19 and V/27 of the 1974 SOLAS Convention, as amended. ECDIS should be capable of displaying all chart information necessary for safe and efficient navigation originated by, and distributed on the authority of, government authorized hydrographic offices. ECDIS should facilitate simple and reliable updating of the electronic navigational chart.

## 3 ELECTRONIC CHART SYSTEM ECS VERSUS ECDIS

Electronic navigation systems are maturely in use across maritime sectors. But not all electronic chart systems have the same capabilities, or function in the same way. The primary differences between the various types of system primary relate to:

- format and contents of the chart data,
- chart display,
- available navigational functions,
- connection with external sensors.

Based on these criteria, there are three basic types of systems:

- Electronic Chart Display and Information System (ECDIS),
- Electronic Chart System (ECS),
- Raster Chart Display System (RCDS).

This section explains what these acronyms mean, what are the capabilities and limitations of each type of system, and what role they can play in a ship's operation. Most large ships use ECDIS as the primary navigation tool. Commercial tugboats, ferries, fishing boats, high-end recreational yachts, and high sophisticated research and specialized vessels use standalone or PC-based navigation systems, often with advanced capabilities not available in ECDIS systems. Electronic navigation is affordable and available through chart plotters and mobile apps to all vessels on the water [Arts, 2003].

For ships' navigating officers, masters and pilots to make the very best decisions concerning the safe navigation of a vessel, they need quality tools, good procedures and training that addresses how to use such tools within the context of making good decisions. Users need to be competent and confident when using information from navigation equipment such as ECDIS, Radar, ARPA, AIS, and electronic position fixing systems GNSS, in order to use them as effective tools.

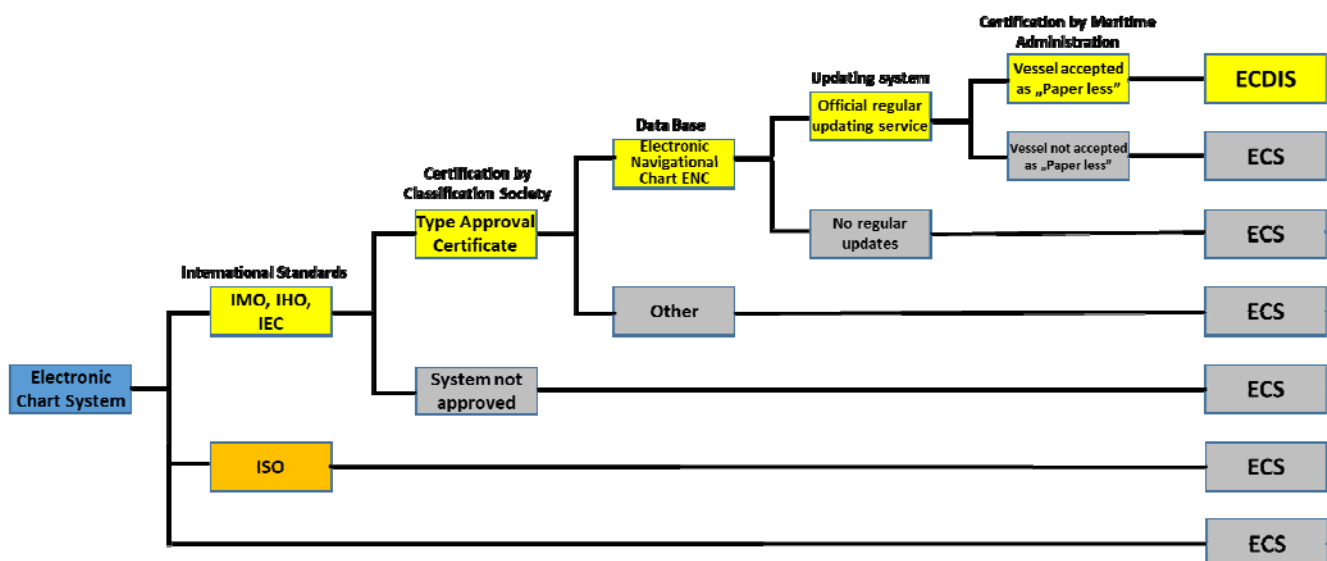

Figure 1. General classification of Electronic Chart Systems ECS aspiring to achieve the IMO status of ECDIS (Electronic Chart Display and Information System) [Weintrit, 2009]

### 3.1 International Standards

The electronic chart system is a relatively new technology that provides significant benefits in terms of navigation safety and improved operational efficiency. More than simply a computer display, an electronic chart system is a real-time navigation system that integrates a variety of information that is displayed and interpreted by the navigator. It is an automated decision aid capable of continuously determining a vessel's position in relation to land, charted objects, aids-to-navigation, and unseen hazards. The electronic chart represents an entirely new approach to maritime navigation. There are two basic types of electronic chart systems. Those that comply with the IMO requirements for SOLAS class vessels, known as the Electronic Chart Display and Information System (ECDIS), and all other types of systems which use navigational charts in digital form, regarded generically as, Electronic Chart Systems (ECS) [Weintrit, 2009; Hecht, et al., 2017].

ECS cannot be the legal equivalent of the paper navigational chart (since it does not meet all the IMO, IHO and IEC standards for ECDIS), is already in widespread use around the world, and is characterized by being physically smaller, less sophisticated, and less expensive than fully compliant ECDIS [Becker-Heins, 2014]. ECS displays different types of chart data (vector or raster) provided by hydrographic office, commercial manufacturer or user. It is intended for the use in conjunction with a current, updated paper chart. It cannot function as an ECDIS system since it does not meet the IMO standards for equipment which is a legal substitute for paper charts.

### 3.2 ECDIS Type Approval

There are almost fifty ECDIS manufacturers on the shipping market, many of which offer more than one model, and some of the key operational features differ widely from one manufacturer to another. Considerable variations in the way different manufacturers display navigation systems have been a cause for concern for several years, prompting calls for a default setting across all models. The IMO's e-Navigation project aims to ensure seafarers are provided with the information they need for safe and efficient navigation, and this includes the development of an "S mode" or standard mode of operation for navigation displays across all manufacturers. The adoption of S-Mode would reduce the risk of confusion when a navigator is faced with a system that they are unfamiliar with [Patraiko, et al., 2010; Hagen, 2017].

Each ECDIS manufacturer should receive type approval certificate for its electronic chart display and information system issued by the Classification Society, e.g. DNV (Det Norske Veritas). In 1999, Transas became the world's first company to receive ECDIS type approval for its Navi-Sailor 2400 system. A relevant certificate resulted from a careful verification procedure and confirmed the product's full compliance with all the necessary international standards and regulations. Since then, this company as well as other ECDIS producers have made a major step forward in maritime software development with

their a new-generation electronic chart system enhanced with a broad array of progressive functions. Such ECDIS producers as Adveto, Consilium, Danelec, Furuno, Imtech, JRC, Kelvin Hughes, Kongsberg, Maris, Martek, Naudeq, OSI, PC Maritime, Raytheon, SAM Electronics, Seall, Simrad, Sodena, Telko, Tokyo Keiki, Transas, Tresco, and many, many others have pioneered the full integration of chart, weather, tidal, UAIS and Radar/ARPA data on a single electronic chart screen. The official DNV recognition of the ECDIS on board system opened new opportunities for potential users of ECDIS already introduced to the marine market. The extended functionality of ECDIS includes integrated weather forecasting, multiple chart display and user-selectable screen layout; all major chart formats; advanced route planning, route monitoring, radar overlay and playback facilities; variable chart display modes; relative and true motion display; and UAIS transponder interface, which makes the system powerful aid for navigation and the core of smart INS (Integrated Navigation System) in combination with other products.

### 3.3 ECDIS Data Base

A fully compliant ECDIS (Paperless) must be using ENC vector charts (also called S-57's in reference to the IHO performance standards publication S-57). Vector charts contain the chart information necessary for safe navigation, and may contain supplementary information in addition to that contained on the paper chart (e.g., Sailing Directions). Vector charts are intelligent, in that systems using them can be programmed to give warning of impending danger in relation to the ship's position and movement. It's best to think of vector charts as a single chart for the entire world that are arranged in layers with each layer being a different scale.

The ENCs themselves are as important as the system that displays them. Again confusion sometimes exists between official ENCs which have to be produced by or on behalf of a government authorized Hydrographic Office, and other commercial electronic charts which, whilst they may be able to be displayed on an ECDIS system, do not comply with the IMO regulations for use as the primary navigational chart system. Only when official ENCs are run in a compliant ECDIS system can it be called an ECDIS. All other chart data used immediately downgrades the system to an ECS, and non-compliant, under the terms of the SOLAS regulations for use of Electronic Charts as a primary means of navigation for merchant shipping [Becker-Heins, 2014; Weintrit, 2009].

The other type of chart is called a Raster Chart; these charts look more like the traditional paper chart and in fact are just a scanned image of a paper chart. These are single charts and like traditional charts must be put in a portfolio and attached to a passage plan within the ECDIS. A ship using Raster Charts is not an ECDIS ship but a RCDS (Raster Chart Display System) ship and must carry paper charts on board as per Appendix 7 of IMO MSC 232.(82) [IMO, 2006] and SN.1/Circ.207.

### 3.4 Updating System

Correcting and upgrading a navigation chart is a constant process. Once a chart is published, constantly changing navigational features and aids or other relevant information have to be promulgated in order to update the ships navigating in those areas. In principle the generation and distribution of regular updates for ENC follows a similar organisational structure to the production and distribution of ENCs. The frequency of updates is normally synchronised with the chart corrections promulgated by national Notice to Mariners (weekly edition) for the affected sea areas. Updates may reach a ship via different ways depending upon the capabilities of the ENC service provider and the communication facilities on board [IHO S-66, 2018]:

- On data distribution media, e.g. CD;
- As an e-mail attachment via SATCOM; and
- As a broadcast message via SATCOM plus additional communication hardware.

Checking charts corrections is quite simple as most systems allow information to be updated via a CD or email supplied by a chart agent on a weekly, monthly basis or quarterly basis. Alternatively all systems have a Chart Correction or Update log, whereby the user can see the corrections applied and date applied. MSC 232.(82) [IMO, 2006]. It is considered that any data which is navigationally significant must be contained in the official ENC updates from the Hydrographic offices which are sent to the ships weekly. If not, data base loses status of electronic navigational chart. If are not received regularly every week, data base loses status of electronic navigational chart.

### 3.5 Paperless Navigation

A mere 30-40 years back, navigators would have scoffed at the idea of Paperless Navigation on big ocean going ships. After all, since centuries, navigational paper charts had been the heart and soul of ship navigation. Imagining that a day would come where we'd no longer have them on board was nothing short of blasphemy. Every single navigating officer who's been out at sea "long enough" still fondly recalls joining vessels with his own treasured chart correction pen. However, the unthinkable did happen. The transition started slowly with smaller vessels like pleasure crafts, tug boats and yachts. But now, armed with the IMO mandate for compulsory ECDIS carriage, the large vessels such as the super tankers and giant container vessels are also running smoothly without paper charts.

In 2005 Simrad launched on the market a new system, the CS68 ECDIS. For the launch of the CS68 ECDIS, Simrad introduced a new phrase to the world of electronic navigation - PLECDIS - or Paper Less ECDIS. The fully approved and redundant nature of the ECDIS meant that no paper charts were required on board. This provided crew and owners benefits in cost and efficiency, and enabled a vessel's navigation to become truly self-sufficient. It provided fully compliant ECDIS functionality, a wealth of value added features and full redundancy.

### 3.6 Assessment and Certification of Paperless Navigation

A shipowners opting for the application of equivalent arrangement concerning ECDIS shall submit all relevant information to their Classification Society in order for them to assess whether the requirements for 'paperless navigation' are met. In addition, the Classification Society conducts a survey on board to verify whether the installation has been installed as per the submitted documentation. As far as the certification is concerned, compliance with the equivalent arrangement concerning ECDIS: it is indicated by means of the Cargo Ship Safety Certificate.

How to determine if the ship is a full ECDIS ship? By checking Form E of the Cargo Ship Safety Equipment Certificate if it's a full ECDIS ship and is not carrying paper charts the backup system will normally say provided. If the backup system is charts it will say nautical charts. However because its listed as an ECDIS ship, doesn't always mean it fully complies. In order for the ECDIS to be compliant it must meet the performance standards as set by the IMO in MSC.232(82) [IMO, 2006].

## 4 ASSESSMENT STANDARD FOR ECS ISO 19379

In order to meet the requirement mentioned above an (international) standard for privately manufactured data was developed over the past twenty years. The standard, ISO 19379, was prepared by Technical Committee ISO/TC8 (Ships and Marine Technology, subcommittee SC6, Navigation) and adopted in 2003. National authorities could consider accepting privately manufactured data meeting ISO 19379 as paper chart equivalent for certain (non-SOLAS) vessels. The US and Italian governments have amended immediately the law to allow fishing vessels and leisure craft fitted with ECS and electronic navigational data that meets the ISO standard, to sail without paper charts in their waters [Malie, 2003].

ISO 19379 is the international standard that specifies the requirements for ECS databases, especially as regards the elements relevant to safety of navigation, such as content, quality and updating. The standard was developed by ISO (International Organization for Standardization), with the contribution of Hydrographic Offices, Classification Authorities, and the Marine Industry, and is being adopted by Maritime Administrations to regulate the use of ECS [Malie, 2003].

ISO 19379 provides guidance on production and testing of an ECS Database. It does not provide detailed coverage of the methods and techniques required for database design and development, nor does it address specific quality management procedures. The standard is applicable to both vector and raster charts. It is envisaged that national regulatory authorities may wish to require compliance with this standard as guidance for data used in ECS or other systems of electronic navigation in their countries. The Standard has been developed to make the ECS chart display as reliable as the official paper chart and its equivalent ENC. The aim has been to develop a standard easy to interpret but

with content and accuracy levels at least equal to those of the ENC of the same area, carefully avoiding, however, any over-specification or rigid structure. The contents of the chart are very much in line with the requirements as described in IHO S-52 "Specifications for Chart Content and Display Aspects of ECDIS" [IHO S-52, 2014].

## 5 ELECTRONIC NAVIGATIONAL CHARTS (ENC) AND ECDIS

Electronic Navigational Chart (ENC) means the database, standardized as to content, structure and format, issued for use with ECDIS by or on the authority of a Government, authorized Hydrographic Office or other relevant government institution, and conform to IHO standards. The ENC contains all the chart information necessary for safe navigation and may contain supplementary information in addition to that contained in the paper chart (e.g. sailing directions) which may be considered necessary for safe navigation [IMO, 2006].

An Electronic Navigational Chart (ENC) is a digital representation of the paper charts, a digital file that contains all the chart information necessary for safe navigation, as well as supplementary information required to plan voyages and avoid groundings (route planning and route monitoring). ENCs are official vector-based electronic charts designed to meet the relevant chart carriage requirements of the SOLAS convention. When displayed within certain parameters, and using a type approved ECDIS, ENCs fully satisfy SOLAS chart carriage requirements, and so can be used as the primary means of navigation.

If we will use the automotive comparison, the ECDIS system is a car, while the maps are fuel. Some cars are for oil, others for gasoline, some for LPG. If

we pour water, beer, milk, wine, coca cola or other liquid into the tank (official, certificated, or not) the car will not move. In the case of ECDIS, these systems are based on vector maps, standardized, official ENCs, using raster charts RNCs we obtain the status of RCDS, but any other database used does not lead to the possibility that we will be able to safe and effective navigate.

### 5.1 What Instead of ENC in the Past? How Did We Fill the Gaps on the Screen?

Raster charts and vector charts of private producers have played a very important role in the past as a fugues, filling gaps on the screen where there were no official electronic navigational charts. In sea areas with no ENC coverage navigators had the choice either of using official raster data or privately manufactured vector data. No doubt the first option offered, next to the use of 'official' charts, the advantage that the number of paper charts carried were considerably reduced, whereas the second required a full set but retained almost full ECDIS functionality (including the alarm functions) that could only be obtained using vector charts.

This option was preferred in the past by several ship owners, particularly those operating their ships globally. Although most ECDIS did support privately manufactured data produced by the major manufacturers, many users preferred (mainly for cost reasons) ECS, particularly as many of these systems met the software requirements laid down in IEC 61174 (ECDIS Operational and Performance Requirements) and were less expensive. In this case, of course, paper charts were used for primary navigation.

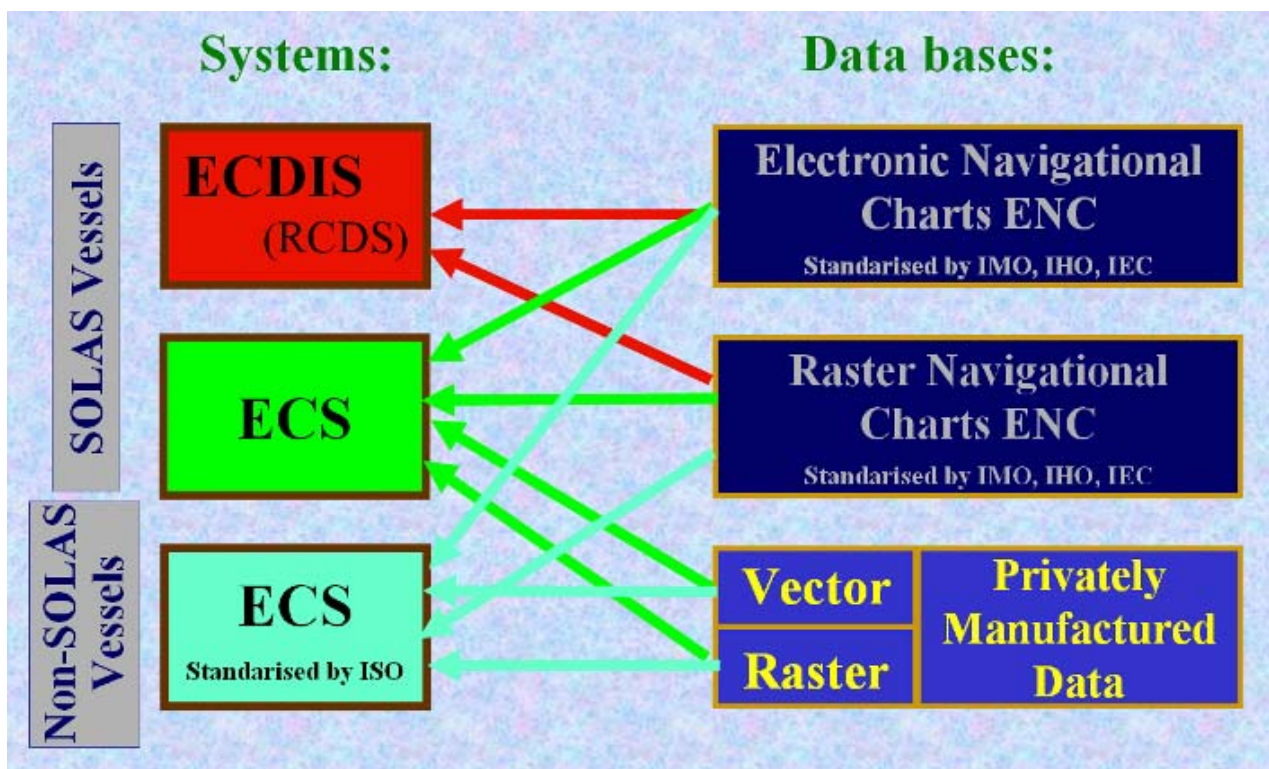

Figure 2. Relationship between electronic chart systems ECS, ECDIS and data bases [Weintrit, 2009, 2010]

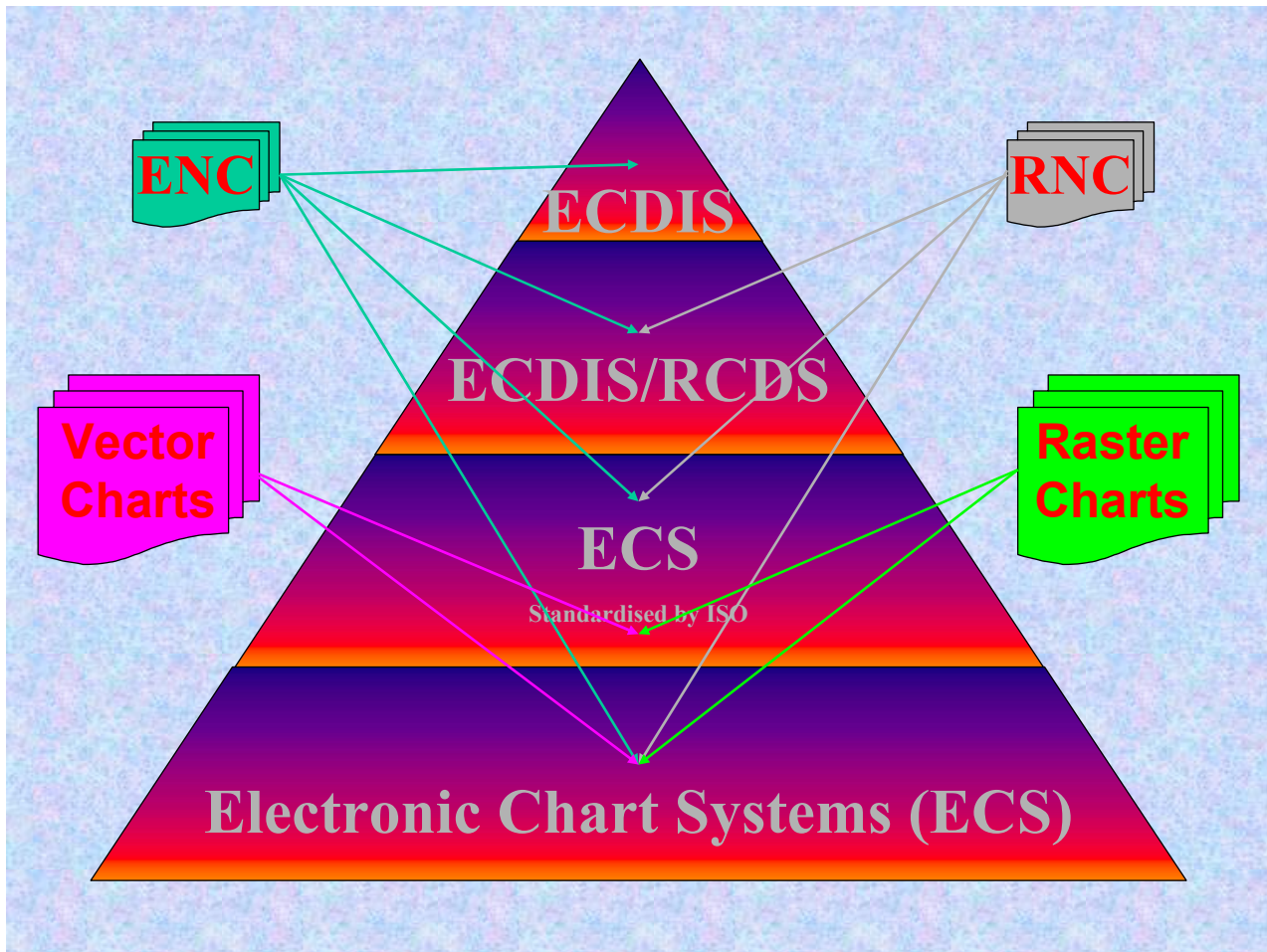

Figure 3. Relationship pyramid between electronic chart systems ECS/ECDIS and data bases [Weintrit, 2009, 2010]

### 5.2 ENC and the Private Data Manufacturers

As mentioned before, there was no doubt that the number of ENCs will increase with time. Although still expensive compared with privately manufactured vector data, prices have come down considerably recently. This may move the market to purchase more ENC. Most helpful is the support of private manufacturers in acting as value-added resellers and in providing ENC in SENC format. Pay special attention on the agreements between Norwegian Hydrographic Service NHS and Jeppesen (former C-Map) and also between UKHO and Transas (TADS - Transas Admiralty Data Service). No doubt that private manufacturers are keen to 'fill the gap' with their own data if necessary.

### 5.3 Mandatory Use of ECDIS

The 1st of July 2018 turned out to be a historic date for chart navigation at sea. On exactly this day ECDIS carriage requirement is now mandated for any new and existing vessel of relevant size on international voyages. This date, however, will not gain any particular reaction from those who are affected and this is due to the applicability and implicitness of technology. It is fair to say that this date marks symbolically that ship navigation has accomplished the principal shift from analogue paper charts to the era of digital chart navigation

The International Maritime Organization (IMO) has made the carriage of ECDIS (Electronic Chart

Display and Information System) mandatory under SOLAS V for most large vessels. This regulatory requirement should not be interpreted as a sign that ECDIS should simply meet the carriage of charts requirement, or indeed that any mariner should be over reliant on global navigation satellite systems (GNSS). The introduction of ECDIS has led to an increasing debate about the importance of 'active' navigation as opposed to 'passive' navigation. The mandatory use of ECDIS is seen to promote increasingly passive navigation and complacency, with paper charts being relegated to just 'reference use' with infrequent plotting of the ship's position onto paper. As a result, too often GNSS is being relied on as the sole means of navigation, what is definitely unprofessional approach.

The ECDIS system can be compared to a musical instrument, due to the large number of different keys and switches it is best for the piano or pianoforte. Unfortunately, only a few, after many weeks or even months of training, will be able to play a concert on their instrument, the rest will play simple scales and easy passages, or usually with one finger tried to play a known melody. Only solid everyday honest work will lead to the proper use of this instrument without producing unexpected squeaks and false sounds. Professional training is very important.

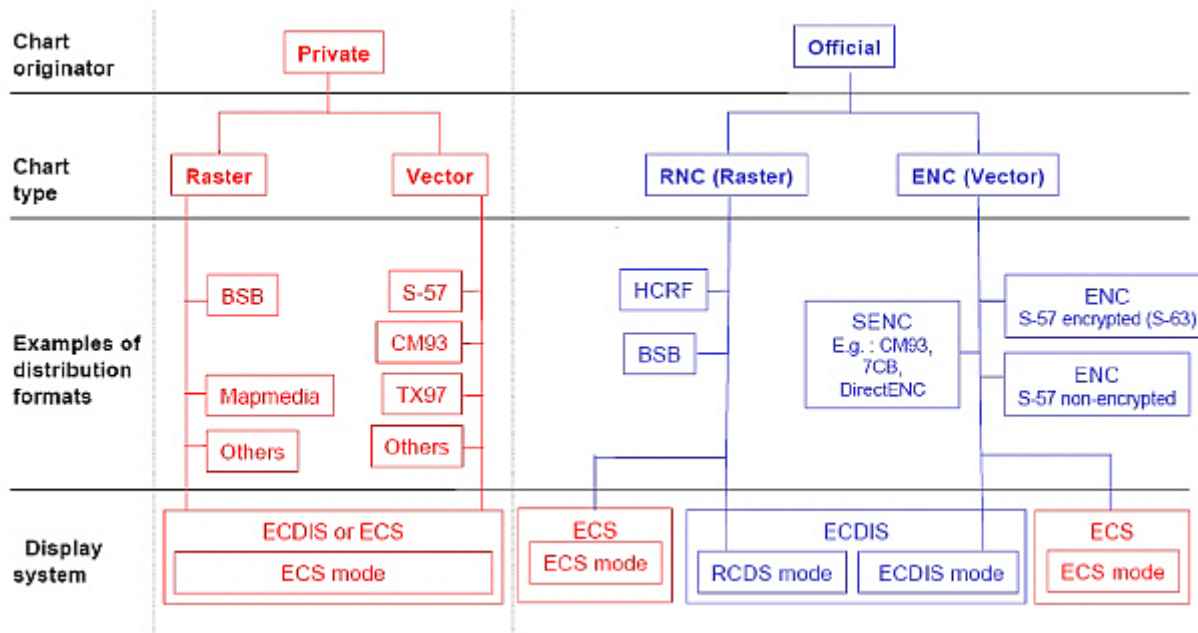

Figure 4. Can chart format names indicate carriage compliance? (IHO S-66, 2018)

#### 5.4 Can Chart Format Names Indicate Carriage Compliance?

There has been much confusion regarding the names used to describe electronic chart distribution formats. The diagram below (Fig. 4) is intended to clarify this. From the diagram it can be seen that the same distribution format can be used for the delivery of both private and official chart data. For example, “BSB” is the term used for the distribution format of US and Canadian RNCs. The same term is also used for the distribution of private raster chart data in other areas (for example, in European waters).

There can also be confusion with ENCs. Private vector chart data delivered in S-57 format does not meet IMO requirements and should never be described as an ENC. Similarly private vector data delivered in a SENC format can be mistaken as being ENCs delivered in the same SENC format.

The most important factor to consider in determining whether data is official is the source rather than the format. The source or originator determines the operational status and the purpose for which the chart data may be used. The combination of the status of the chart data and the functionality of the particular device finally determines whether an electronic chart navigation “system” is operating as an ECDIS or as an ECS.

#### 5.5 Examples of Electronic Chart Formats

Many ECS systems are able to use ENC or RNC data, however even when using official charts they may not be used to fulfil ECDIS carriage requirements in accordance with SOLAS chapter V

Examples of format names used by private data producers:

- CM-93 chart data produced by Jeppesen Marine (previously known as C-Map),
- TX-97 vector chart data produced by Transas,

- BSB Raster chart format used by, for example, the USA and Canada.

### 6 PROS AND CONS OF ECDIS OR PAPERLESS NAVIGATION OF SHIPS

We cannot deny the fact that ECDIS does have an edge over paper charts. Let’s discuss some of the pros and cons of paperless navigation. When it comes to electronic navigation, an emphasis on understanding the possible anomalies of the ECDIS system entirely should always be in mind. Therefore, a change in the mindset of navigation is required for understanding ECDIS limitations and possibilities, including its benefits and disadvantages. Only with an ECDIS-oriented mindset, the navigator will efficiently integrate the system in the ongoing navigational process. Taking everything into consideration, the navigator should be adequately prepared and vigilant to monitor problems, assess hazards and consider control measures for the system in order to gain the benefits from electronic navigation [Herwadkar, 2017].

#### 6.1 The Cons (Disadvantages)

What may go wrong?:

- Over-Reliance. With an equipment which is seemingly fool-proof, there is a tendency for navigators to over rely on it. No matter how good the ECDIS is, its performance still largely depends upon the inputs. The purpose of the ECDIS is to facilitate efficient navigation, not to substitute it.
- Information Overload. Too much information on screen may cause clutter and can be distracting. The navigator may lose critical minutes on non-important items while decisions should be taken.
- Complacency due to automatic plotting of position. As positions on paper charts were “past positions” the navigator continually checked them

again and again. Now the real time position creates a false safe emotion and the feeling that a last time response will be enough.

- Garbage In - Garbage Out (GIGO): ECDIS at the end of the day, is a machine and depends solely on the type of inputs that it receives. Erroneous position inputs from the GPS or loss of GPS signal can have grave consequences with the ECDIS going in DR mode. If the alarm is missed out, the result can be disastrous. Hence, it is vitally important to check the performance of sensors and to carry out frequent comparisons between the primary and secondary means of position fixing. Other inputs such as the Gyro, Log, Echosounder, Navtex, etc. should be frequently verified independently to ensure smooth operation.
- Wrong settings. Considering that ECDIS is an equipment system, if wrong settings are installed, the information provided to navigator will not be accurate. Feeding in wrong parameters for safety critical settings such as the Safety Depths, Safety Contours etc can give a false sense of safety. It is extremely important that the Master himself checks these settings each time they are changed. These settings should be password protected and every navigator should verify them each time prior taking over the watch. Alarms should not be deactivated without strong reason and never just for the sake of avoiding frequent alarms. All the alarms in use should be properly documented and their switching on and off should be controlled by a defined procedure
- Alarm Fatigue. If alarms start going off too frequently, the navigator could end up in a dangerous situation called Alarm Deafness. This leads to the watch keeper acknowledging the alarm even without checking what it was. He will eventually run out of luck and there could be an occasion where he might miss out on a critical warning such as approaching shallow contour. Hence, alarms should be carefully chosen which are appropriate to the prevailing conditions. Every single alarm should be checked and investigated prior acknowledging.
- Different Types. Navigation on paper charts was a skill which had to be mastered just once. It was then just routine practice which kept one in tune with things. However, this does not happen with ECDIS. Different vessels will have different types of ECDIS equipment. Even if the essential features are the same, it still takes a lot of fiddling around until one gets comfortable with the machine.
- Anomalies: Every navigator needs to be aware of the anomalies present in that particular equipment. It could be a simple use of the SCAMIN (Scale Minimum) function or something serious where certain depths or symbols might not be visible at a particular scale or appear differently. Complete familiarisation with the ECDIS equipment is a must.
- Resistance to Change: Although this sounds like a trivial issue, it can be quite problematic. Most of the present day navigators have grown up in an era where paper charts was the only means of navigation. Not having these onboard could for them mean not having an aid on which they have relied all their lives. The transition cannot be easy and this could create a mental block for many.

Hence it is vital, that senior navigators embrace this new technology with open arms and do their bit to improve the process of change.

- Lack of ENC's for certain trading areas which require the additional paper charts carriage.

## 6.2 The Pros (Advantages)

Benefits of ECDIS use:

- Reduced workload for the navigator (charts and nautical publications updating, voyage planning, all information in "one hand").
- Easy Correction of charts and publications. All experienced navigators may recall in their mind the endless hours of chart and publication corrections. Before the advent of paperless navigation, the largest chunk of the Navigating Officer's work time was consumed in Correcting Charts. The Navigating Officer now receives weekly updates to the Electronic Charts via Email which he has to download onto a zip drive and upload them to the ECDIS. Even the dreaded T&P notices are now shown electronically on the ECDIS.
- Navigation in real time. One of the single biggest advantages of the ECDIS over paper charts is its ability to enable the user to see the vessel's position in real time without user action. Navigation in real time increasing situational awareness in combination with proper lookout. With the ECDIS system the position display on the chart is the present position. When the paper charts used the position plotted on the chart was the position at the time it was received several minutes ago.
- Accuracy. As many systems are mixed and analysed the result of actual position and advanced movement is more accurate.
- Easy route planning. Route planning is much easier, interactive and less time-consuming.
- Easy route monitoring, with all required information displayed in short time. Though ECDIS has now evolved into a full-fledged primary source of navigation, it was born as an Anti-Grounding aid to Navigation. Even to this day, the ability of the ECDIS to warn the user of approaching shallow waters make it one of the most useful equipment on the bridge. The user has complete flexibility to determine these safety settings on the ECDIS. While there are certain safety critical alarms that are ON by defaults and cannot be changed, there are a host of other alarms and warnings which may be switched on or off by the User depending on the situation.
- Prediction of special manoeuvres (predicted path, trial manoeuvre, docking mode). All the systems also include Man Overboard function and search and rescue functions providing information quickly without much searching.
- • Availability of charts, especially those charts required for not programmed voyages. One of the great advantages of ECDIS over paper charts is the availability of electronic charts – especially when voyage orders are received at the last minute.
- • Access to additional information resources.
- • Cost Efficient. Although, electronic charts are by no means cheap, they still have an edge over paper charts dollar for dollar. Electronic Chart Permits



are obtained electronically with minimum data usage. Paper charts though, have to be delivered physically which involved handling fees by the agents, especially if ordered at the last minute. All this can be avoided by using Electronic Charts.

## 7 DIFFERENCES BETWEEN RASTER CHART DISPLAY SYSTEM (RCDS) AND ECDIS

Raster Chart Display System. Raster Chart Display System (RCDS) means a navigation information system displaying RNCs with positional information from navigation sensors to assist the mariner in route planning and route monitoring, and if required, display additional navigation-related information.

The RNCs are raster charts that conform to International Hydrographic Organization (IHO) specifications and are produced by digitally scanning a paper chart image. The image may be either the finished chart itself or the stable colour bases used in the multi-colour printing process. The resulting digital file may then be displayed in an electronic navigation system where the vessel's position, generally derived from electronic position fixing systems, can be shown. Since the displayed data are merely a digital photo-copy of the original paper chart, the image has no intelligence and, other than visually, cannot be interrogated.

The mariners' attention is drawn to the following limitations of the RCDS mode [IMO, 2006]:

- Unlike ENC, where there are no displayed boundaries, RNCs are based on paper charts and as such have boundaries which are evident in ECDIS;
- RNCs will not trigger automatic alarms (e.g. anti-grounding). However, alarms and indications can be generated with the manual addition, during passage planning, e.g. of clearing lines, ship safety contour lines, isolated danger markers and danger areas to mitigate these limitations;
- Horizontal datums and chart projections may differ between RNCs. Mariners should understand

how a chart's horizontal datum relates to the datum of the position fixing system in use. In some instances, this may appear as a shift in position. This difference may be most noticeable at grid intersections;

- A number of RNCs cannot be referenced to either WGS-84 or PE 90 geodetic datums. Where this is the case, ECDIS should give a continuous indication;
- The display of RNCs features cannot be simplified by the removal of features to suit a particular navigational circumstance or task at hand. This could affect the superimposition of radar/ARPA;
- Without selecting different scale charts the look-ahead capability may be limited. This may lead to inconvenience when determining range and bearing or the identity of distant objects;
- Orientation of the RCDS display to other than chart-up, may affect the readability of chart text and symbols (e.g. course-up, route-up);
- It is not possible to interrogate RNC features to gain additional information about charted objects. Whether using ENC or RNC, in the planning process a mariner should consult all relevant publications (such as sailing directions, etc.);
- With RNC, it is not possible to display a ship's safety contour or safety depth and highlight it on the display unless these features are manually entered during route planning;
- Depending on the source of the RNC, different colours may be used to show similar chart information. There may also be differences in colours used during day and night time;
- An RNC is intended to be used at the scale of the equivalent paper chart. Excessive zooming in or zooming out can seriously degrade the displayed image. If the RNC is displayed at a larger scale than the equivalent paper chart, the ECDIS will provide an indication; and
- ECDIS provides an indication in the ENC which allows a determination of the quality of hydrographic the data. When using RNCs, mariners are invited to consult the source diagram or the zone of confidence diagram, if available.

### Operational Status

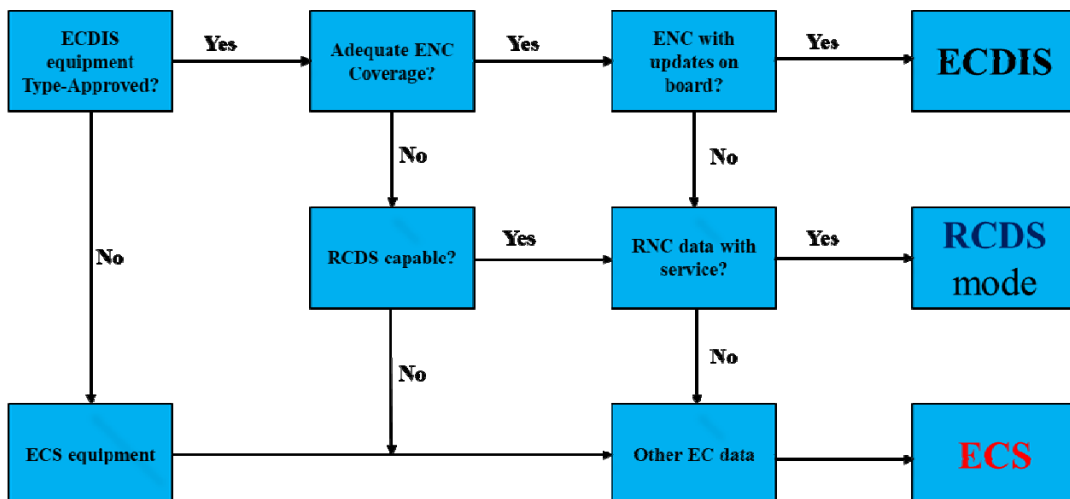

Figure 5. Operational status of ECDIS [Weintrit, 2009]

## 8 OTHER TYPES OF ELECTRONIC CHART SYSTEMS

### 8.1 *Warship Electronic Chart Display and Information System (WECDIS)*

The concept of additional military layers (AML) was introduced in 1995 with the intent to define a standardized format for non-navigational data. Since 1995, various North Atlantic Treaty Organization (NATO) standardization agreement documents concerning AML data and warship electronic chart display and information systems (WECDIS) have been created. NATO has since endorsed a few AML product specifications, and completed sea trials using AML datasets. However, as more nations move toward AML data production, not too much is known about how the data will perform as overlays within a WECDIS adhering to NATO WECDIS standards.

Using precise military integrated navigation system the sophisticated electronic chart system designed to meet the specific navigational demands of the military market, the strengths and weaknesses of how AML data interacts with other data types, primarily ENC data, within the WECDIS were identified. As stated in the WECDIS standard, a WECDIS means "an ECDIS as defined by the International Maritime Organization (IMO), with additional functionality for navigation and conduct of warfare on board war-ships". We might also consider referring to the concept of Marine Information Overlays (MIO) which have been used in the Marine Electronic Highway project, and whose use are gathering support within the e-Navigation discussion.

### 8.2 *Inland ECDIS*

Inland ECDIS (I-ECDIS) is a system for the display of electronic inland navigation charts and additional information. Its purpose is to contribute to safety and efficiency of inland navigation and thus also to protection of the environment. Simultaneously Inland ECDIS is to reduce the workload when navigating the ship as compared to traditional navigation and information methods. Inland ECDIS provides also the basis for other River Information Services (RIS), e.g. Inland AIS.

The Inland ECDIS standard provides a uniform basis for the use of electronic inland navigation charts and for the use of telematics applications like Inland AIS transponders or other methods of identifying, tracing and tracking of vessels on inland waterways. It contains the technical and operational requirements, testing methods and required test results for Inland ECDIS applications.

Inland Electronic Navigational Charts (IENCs) are official digital vector charts produced by inland waterway authorities in accordance with the International Hydrographic Organisation's (IHO) product specification S-57 [IHO S-57, 2014], extended for use on inland waterways. Inland ENC (IENC) means the database, standardized as to content, structure and format, issued for use with Inland ECDIS. The Inland ENC complies with the IHO standards S-57 and S-52 [IHO S-52, 2014], enhanced by the additions and clarifications of this standard for

Inland ECDIS. The Inland ENC contains all essential chart information and may also contain supplementary information that may be considered as helpful for navigation [Weintrit, 2010]. IENCs follow the IHO S-57 data exchange standard, which is recognized by software vendors and government hydrographic offices for electronic chart applications.

Because of the technical similarity between IENCs and SOLAS ENCs, both can usually be displayed on both ECDIS and inland navigation systems. However, the inland IENC standard is a superset of the ENC standard. Therefore, an ECDIS system will not normally display inland waterway specific objects and symbols correctly.

## 9 NAVIGATION TERMINOLOGY AND ICONS OF FUNCTIONS RELATED TO ECDIS

The IMO is working on Guidelines on Standardized Modes of Operation, S-Mode [IMO, 2018]. These draft guidelines apply to Integrated Navigation Systems (INS), Electronic Chart Display and Information Systems (ECDIS) and Radar equipment. They may be applied to other electronic navigation equipment, and navigation sensors where applicable, where it would improve standardization and usability. The aim of these elaborated guidelines is to promote standardization of user interfaces to help meet user needs. The guidance within these guidelines has been developed in close collaboration with an international association of equipment manufacturers to ensure its efficient implementation. Improved standardization of the user interface and information used by seafarers to monitor, manage and perform navigational tasks will enhance situation awareness and safe and effective navigation.

In one of appendix to these guidelines were identified commonly-used functions on navigation equipment and for each function specified the associated terminology, abbreviation and (where appropriate) icons. These terms, abbreviations and icons of functions (hot keys and shortcuts), if available, are recommended to be used for the display of navigation-related information, to promote consistency of presentation across navigational equipment.

Where icons, terms and/or abbreviations are used, they must meet the requirements of this appendix. Where a standard term, abbreviation, or icon is not available, another icon, term or abbreviation may be used, but these should not conflict with those listed in the appendix.

The icons specified may indicate a status, may execute a specific function (hot key), or may provide access to a group of related functions (shortcut). Only the shape of the icon was specified; this appendix does not specify a colour scheme for icons.

In Table 1 are presented icons of functions related to ECDIS, proposed by IMO expert group.

Table 1. Proposed icons of functions related to ECDIS [IMO, 2018]

Explanation	Term	Abbreviation	Icon (hot key)
To select ECDIS mode (for multi-function displays)	ECDIS	ECDIS	
To export route plan	Export Route	RTE EXPORT	
To import route plan	Import Route	RTE IMPORT	
To toggle radar overlay	Radar overlay	RADAR OVR	
To provide additional mariner's information.	User Chart	USR CHT	
To access route plan functionality	Route planning	ROUTE PLAN	
To access route monitoring functionality	Route monitoring	ROUTE MON	
To add or remove information from the ECDIS display	Chart display settings	CHART DISP SET	

Table 2 presents author's proposal for an icon that allows to select the ECDIS mode. Unfortunately, it was not accepted by most IMO's expert group. According to the author, it was much better to use an icon with three fields marked on ECDIS screen: Electronic Chart Area, Information Area and Main Menu Area. In addition, we could mark the motion vector with position information.

Table 2. Icon for ECDIS proposed by Author

Explanation	Term	Abbreviation	Icon (hot key)
To select ECDIS mode (for multi-function displays)	ECDIS	ECDIS	

## 10 CONCLUSIONS

It is nice to announce that the project of an international implementation of ECDS for ships has been fully realized. Of course there is still a lot to do, but paperless navigation has become a reality.

Although, perhaps a bit biased towards the old school paper chart navigation, we cannot deny the fact that ECDIS does have an edge over paper charts. When it comes to electronic navigation, an emphasis on understanding the possible anomalies of the ECDIS system entirely should always be in mind. Therefore, a change in the mindset of navigation is required for understanding ECDIS limitations and possibilities, including its benefits and disadvantages. Only with an ECDIS-oriented mindset, the navigator will efficiently integrate the system in the ongoing navigational process.

Taking everything into consideration, the navigator should be adequately prepared and vigilant to monitor problems, assess hazards and consider control measures for the system in order to gain the benefits from electronic navigation, simply play smoothly, using music notes. Training is extremely important. Practice makes perfect. As we said ECDIS is like a musical instrument, a piano. Only those who practice on it every day, in a few years will play a concert on it, the rest will falsify mercilessly or play simple melodies, scales and passages for the rest of their lives.

The main fields of ECDIS benefits are the following: efficient updating, route monitoring, situational awareness, route planning, safety alarms, voyage recording, and paper chart reduction. Mortimer Rogoff, one of the pioneers in the development of Electronic Chart Systems, President of NECSA (Navigational Electronics Charts System Association), said in 1992: "Two of the newest navigation stars for ships can't be found in the Nautical Almanac: GPS and electronic chart display and information system (ECDIS). Individually, GPS tells you your location and ECDIS shows it to you". In 2000 Lee Alexander, professor University of New Hampshire, an internationally recognised expert in electronic charting, added: "A paper chart shows you where you were, or shouldn't be. ECDIS tells you where you are, and can safely go" [Weintrit, 2009]. These are two important timeless declarations.

All systems, which are not checked to show compliance with the ECDIS Performance Standards, can be generically designated as "Electronic Chart Systems" (ECS). An ECS may be able to use either official ENC's, RNC's or other chart data produced privately and could have functionality similar to ECDIS, but can't be legal equivalent of paper charts.

Some ECS equipment manufacturers also produce vector and raster data to use in their products. These suppliers have been producing private chart data for a number of years and have established themselves in the market. They were the pioneers and have established the idea and the use of electronic chart systems on vessels. Their charts are derived from Hydrographic Office paper charts or Hydrographic Office digital data. Regardless of that, where the vessel operates with ECS, the paper chart remains the official basis for navigation on board. The vessel must retain and use a full folio of up-to-date paper charts on board, regardless of the type of electronic charts used. ECS is not intended to meet SOLAS requirements, there are no IMO Performance Standards for ECS.

The IMO elaborates the guidelines for the standardization of user interface design for navigation equipment, including ECDIS. These guidelines stem from a compelling user need for greater standardization to enhance usability across navigation equipment and systems. Significant variation between systems and equipment produced by different manufacturers has led to inconsistency in the way essential information is presented, understood and used to perform key navigation safety functions. Improved standardization of electronic chart systems will provide users with more timely access to essential information and functions that support safe navigation.

The classification of electronic chart systems was presented taking into consideration the following criteria: international standards, certification by classification society, used data base, updating system, certification by maritime administration, and specific user needs.

## REFERENCES

- Arts, G. (2003). A Chart Distributor Perspective. The failure of ECDIS versus the apparent success of ECS. *Hydro International*, Vol. 7, No. 2, March.
- Becker-Heins, R. (2014). ECDIS Basics. A Guide to the Operational Use of Electronic Chart Display and Information Systems. Geomares Publishing, Lemmer, The Netherlands.
- Edmonds D. (2007): 10 Things They Should Have Told You About ECDIS. *TransNav, the International Journal on Marine Navigation and Safety of Sea Transportation*, Vol. 1, No. 1, pp. 71-76.
- Hagen, J.E.(2017). Implementing e-Navigation. Artech House, Boston – London.
- Hecht, H., Berking, B., Jonas, M., and Alexander, L. (2017). The Electronic Chart: Functions, Potential and Limitations. A textbook for ECDIS use and training, 4<sup>th</sup> Edition. Geomares.
- Herwadkar H. (2017). Pros and Cons of ECDIS or Paperless Navigation Of Ships. *Marine Insight*, 30 September 2017, <https://www.marineinsight.com/marine-navigation/pros-and-cons-of-eedis-or-paperless-navigation-of-ships/>
- IHO S-52, (2014). Specifications for Chart Content and Display Aspects of ECDIS. Edition 6.1. International Hydrographic Organization, Monaco, October.
- IHO S-57, (2014). IHO Transfer Standard for Digital Hydrographic Data. Supplementary Information for the Encoding of S-57 Edition 3.1 ENC Data. Supplement No. 3 to Edition 3.1, IHO, Monaco, June.
- IHO S-66, (2018). Facts about Electronic Charts and Carriage Requirements. Edition 1.0.0, International Hydrographic Organization, Monaco, January.
- IMO MSC.232(82), (2006). Revised Performance Standards for Electronic Chart Display and Information Systems (ECDIS). International Maritime Organization, London, 5 December.
- IMO NCSR 6/7, (2018). Guidelines on Standardized Modes of Operation, S-Mode. Report of the Correspondence Group submitted by Australia. International Maritime Organization London, 16 October.
- Malie, C. (2003). ENC or Privately Manufactured Data. One or The Other or Both? *Hydro International*, Vol. 7, No. 2, March.
- Patraiko, D., Wake, P., Weintrit, A. (2010). e-Navigation and the Human Element. *TransNav, the International Journal on Marine Navigation and Safety of Sea Transportation*, Vol. 4, No. 1, pp. 11-16.
- Smith, S.M. (2018). ECDIS and ENCs Are Here. Now What? *Hydro International*, Vol. 22, No. 3, May/June.
- Weintrit, A. (2001). The Electronic Chart Systems and Their Classification. *Annual of Navigation* No. 3/2001. Polish Academy of Sciences, Polish Navigation Forum, Gdynia, Poland.
- Weintrit, A. (2009). Handbook on Operational Use of ECDIS, A Balkema Book, CRS Press, Taylor & Francis Group, Boca Raton, London, New York, Leiden.
- Weintrit, A. (2010). Six in One or One in Six Variants. Electronic Navigational Charts for Open Sea, Coastal, Off-Shore, Harbour, Sea-River and Inland Navigation. *TransNav, the International Journal on Marine Navigation and Safety of Sea Transportation*, Vol. 4, No. 2, pp. 165-177.
- Weintrit A. (2015). ECDIS issues related to the implementation of the carriage requirements in SOLAS Convention. *Archives of Transport System Telematics*, Vol. 8, p. 35-40.
- Weintrit, A. (2018). Accuracy of Bathymetric Data in Electronic Navigational Charts. *Scientific Journals of the Maritime University of Szczecin*, No. 55 (127), pp. 60-69.